

Tav. 1

FERRO

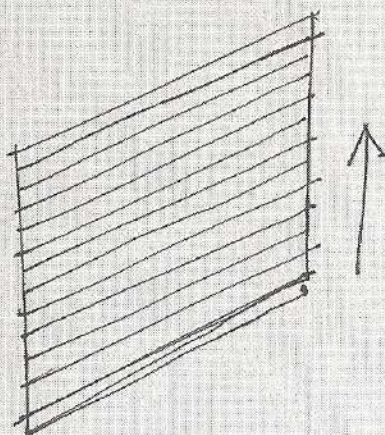

SIPARIO DI FERRO  
TAGLIAFUOCO  
(ISOLA ERMETICAMENTE  
DALLA SALA)

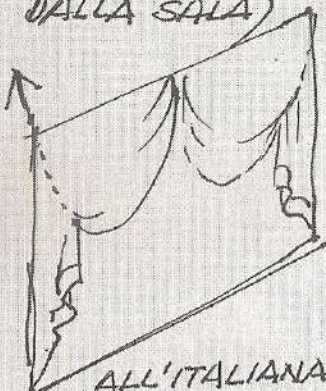

ALL'ITALIANA  
E ALL'IMPERIALE QUANDO  
SCOMPARE COMPLETAMENTE

TELA CON  
IMPRIMITURA  
E COLORI

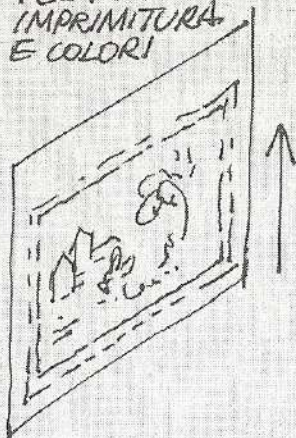

SIPARIO STORICO  
(NELLE SERATE  
DI GALA -  
RAPPRESENTA SPESSO  
SCENE MITOLOGICHE  
O INTERPRETA FATTI  
STORICI CITTADINI)

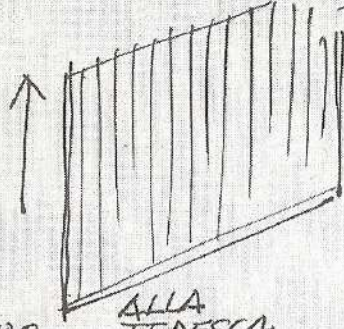

ALLA  
TEDESCA

VELLUTO

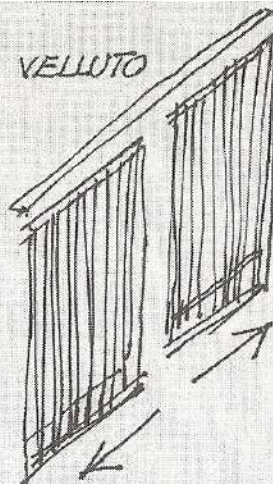

SIPARIO ALLA GRECA

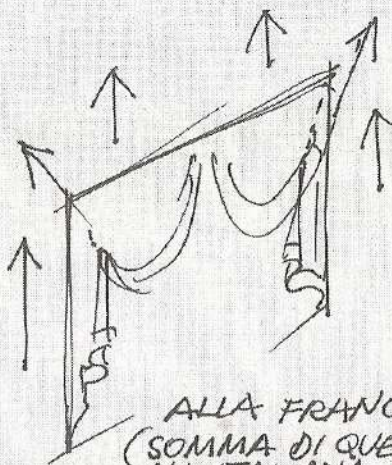

ALLA FRANCESE  
(SOMMA DI QUELLO  
ALL'ITALIANA  
E TEDESCA)



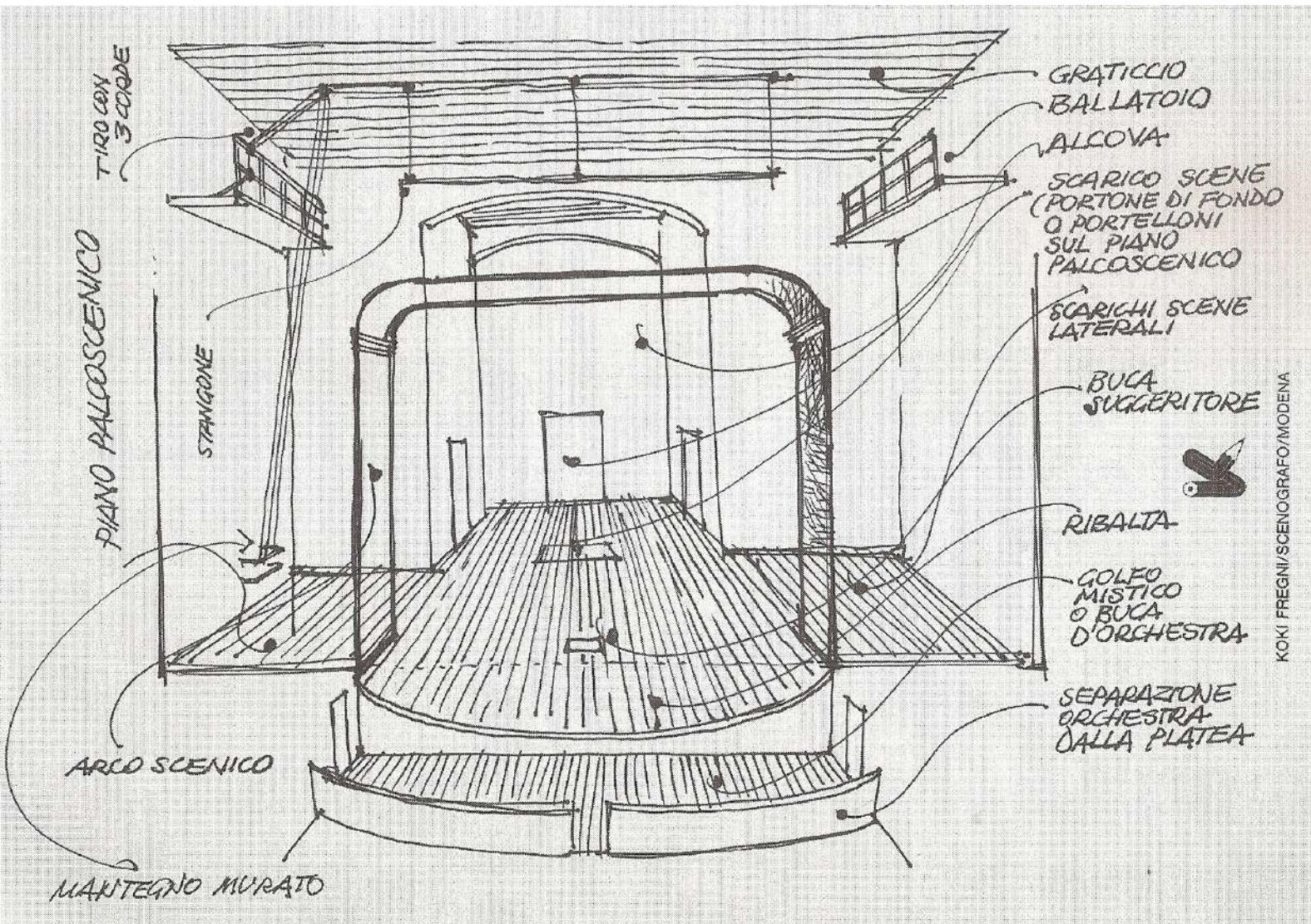

Tav. 3

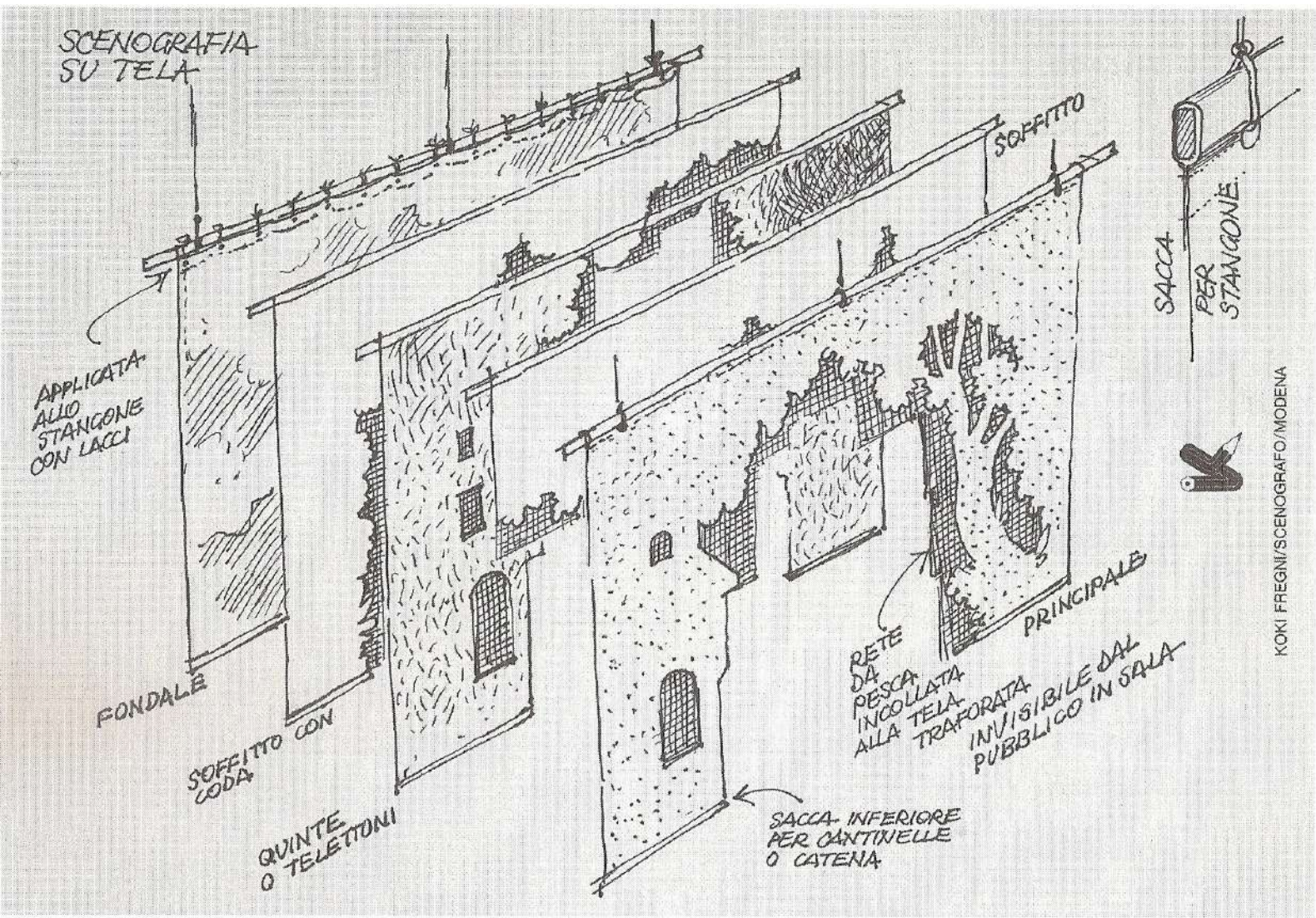

Tav. 4

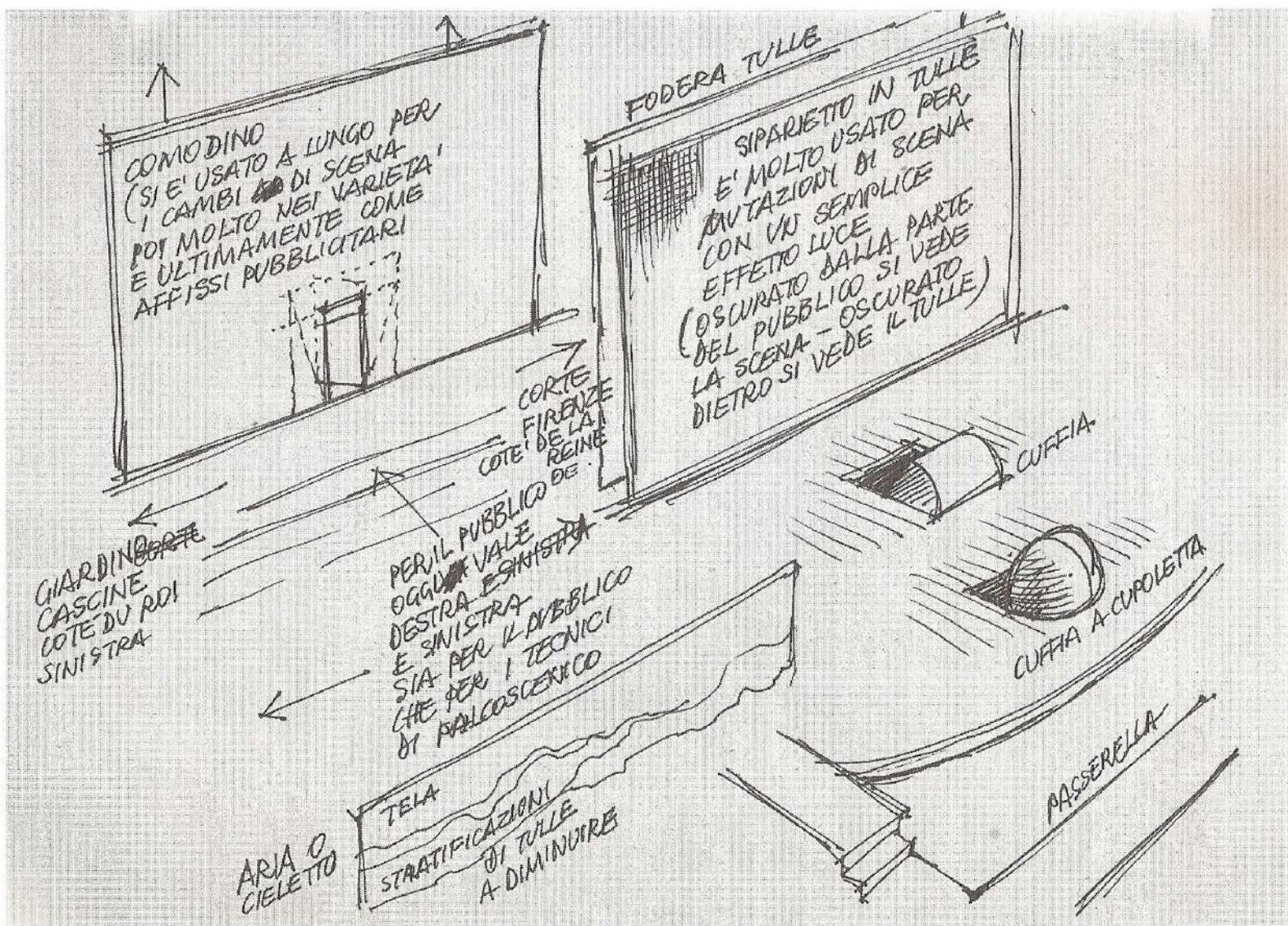

Tav. 5

INQUADRATURA GENERICA  
(O MUTA) IN PANNI O VELLUTO  
SPESSO NERO - ADATTO A BALLETTI

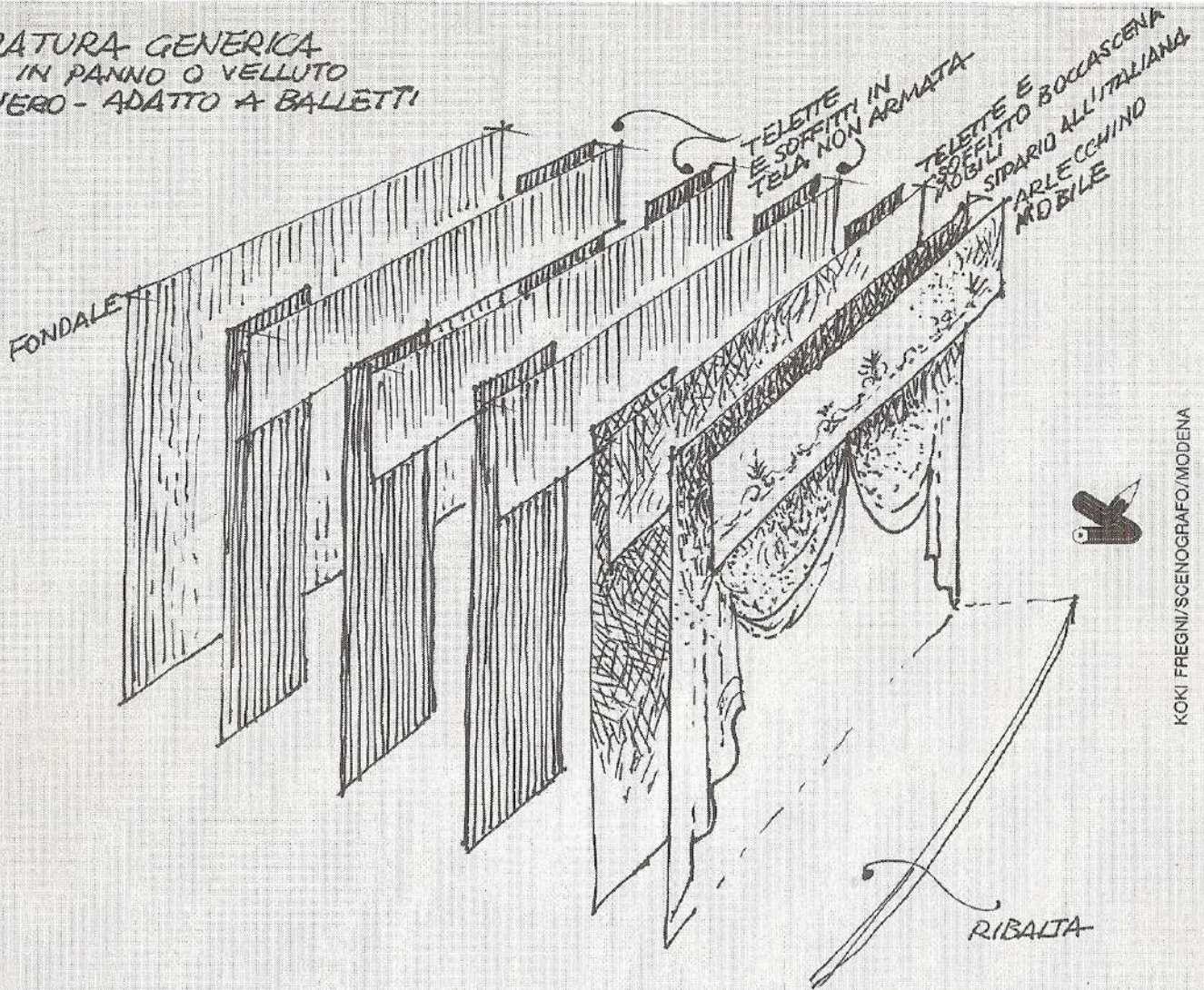

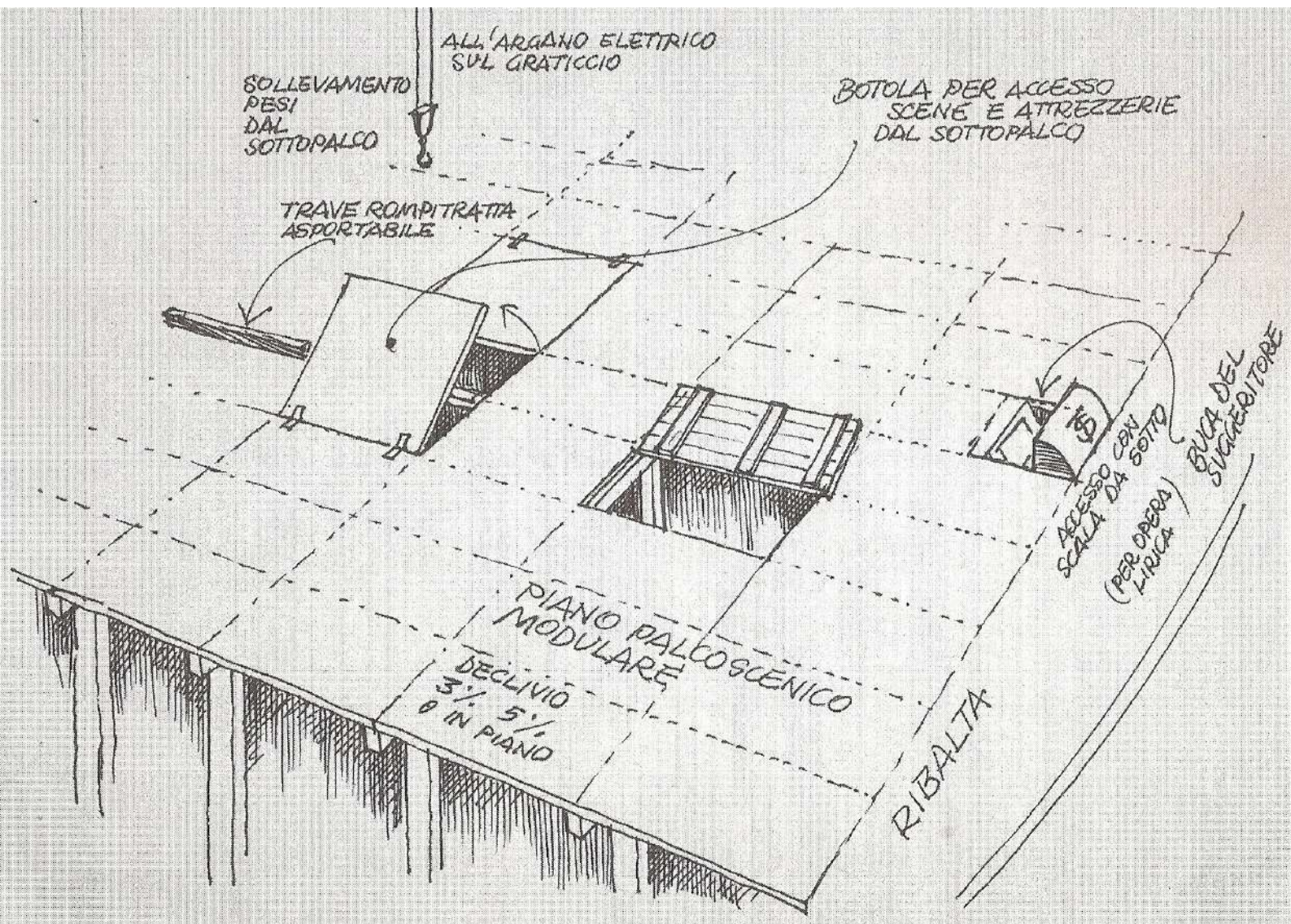

Tav. 7

GRATICCIO IN FERRO  
 IN USO IN MOLTI TEATRI  
 CONTEMPORANEI

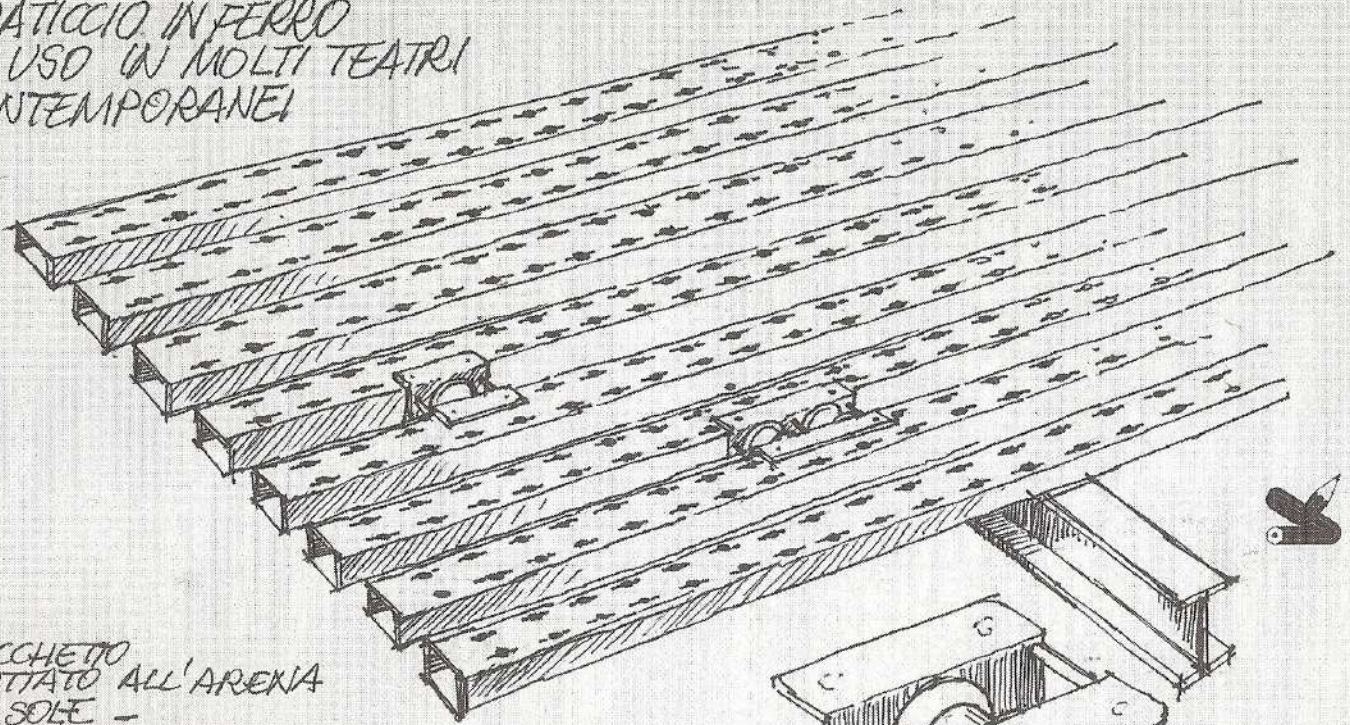

ROCCHETTO  
 ADOTTATO ALL'ARENA  
 DEL SOLE -

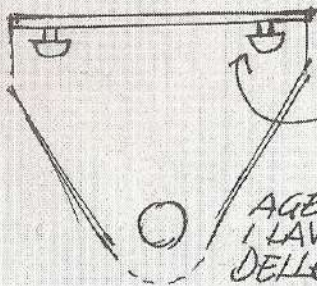

AGEVOLA  
 I LAVORI  
 DELLE CORDE

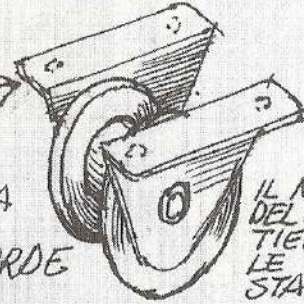

IL MOZZO  
 DEL ROCCHETTO  
 TIENE VINCOLATE  
 LE  
 STAFFE!

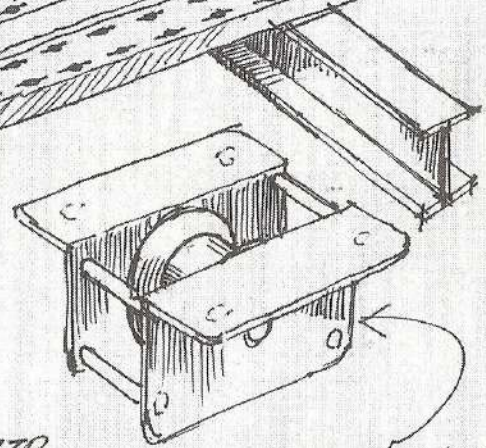

ROCCHETTO DI SERIE  
 IN ACCIAIO -  
 DISCUTIBILI I PERNI  
 DI ACCANCIO DUE STAFFE



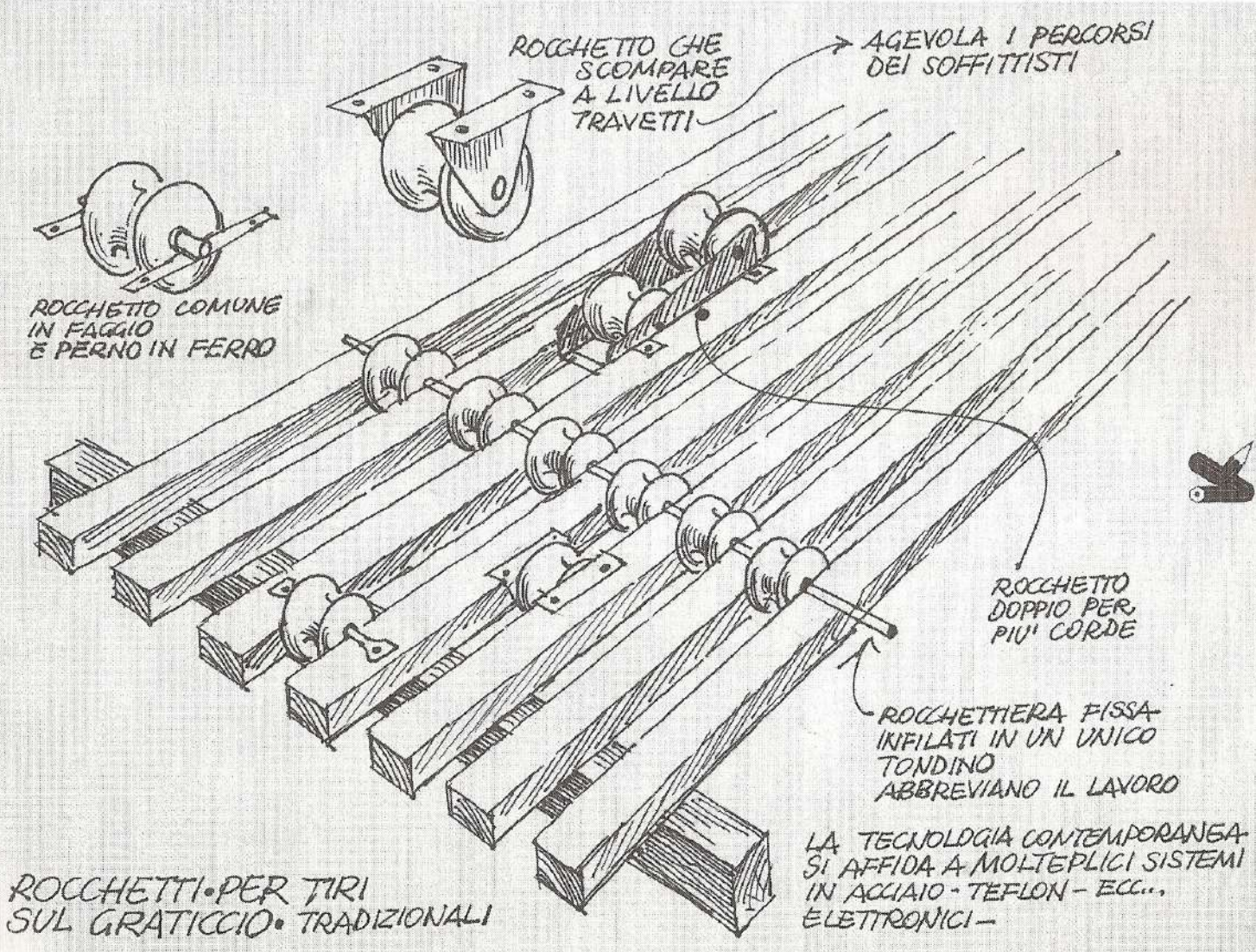

Tav. 9

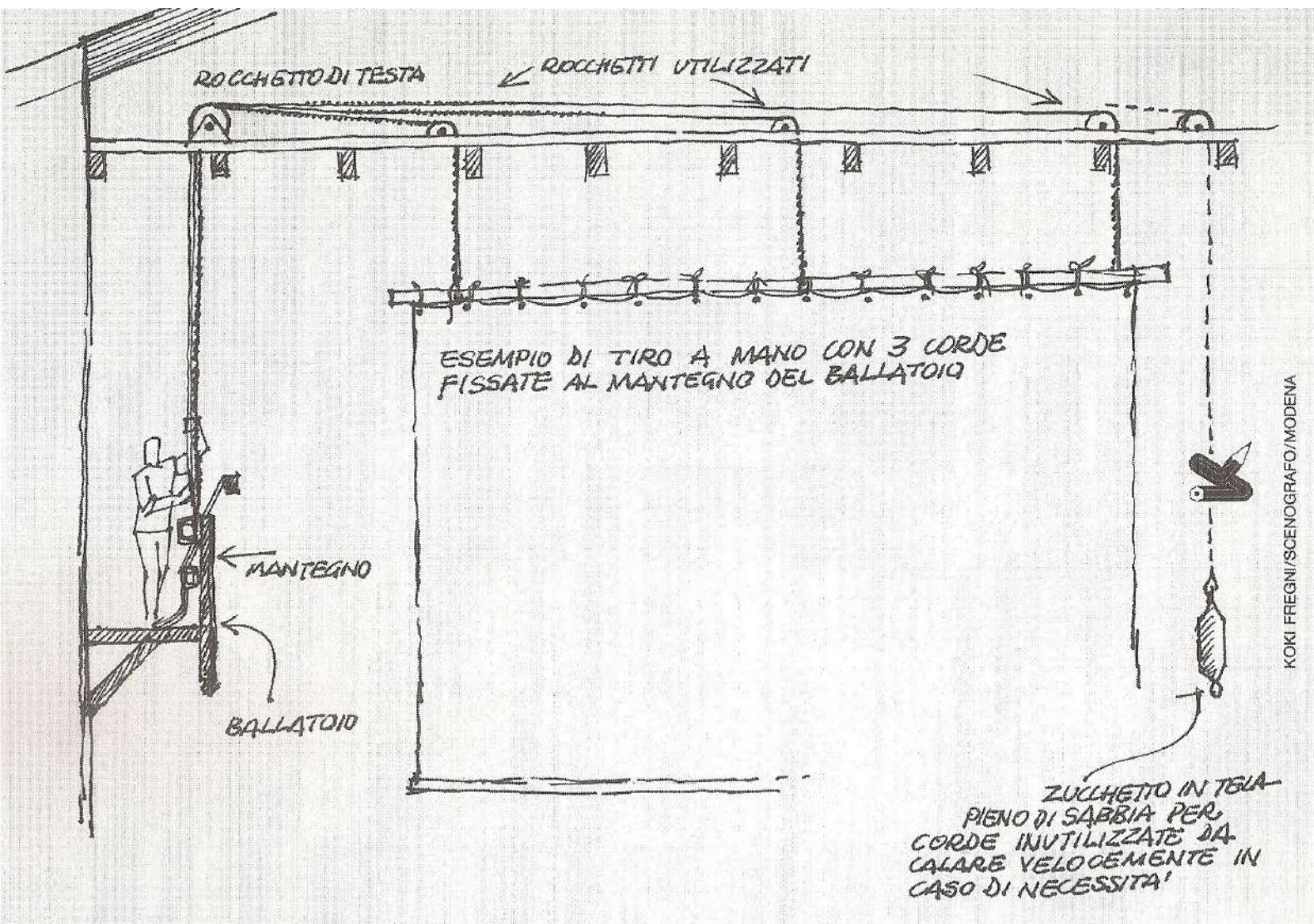

Tav. 10

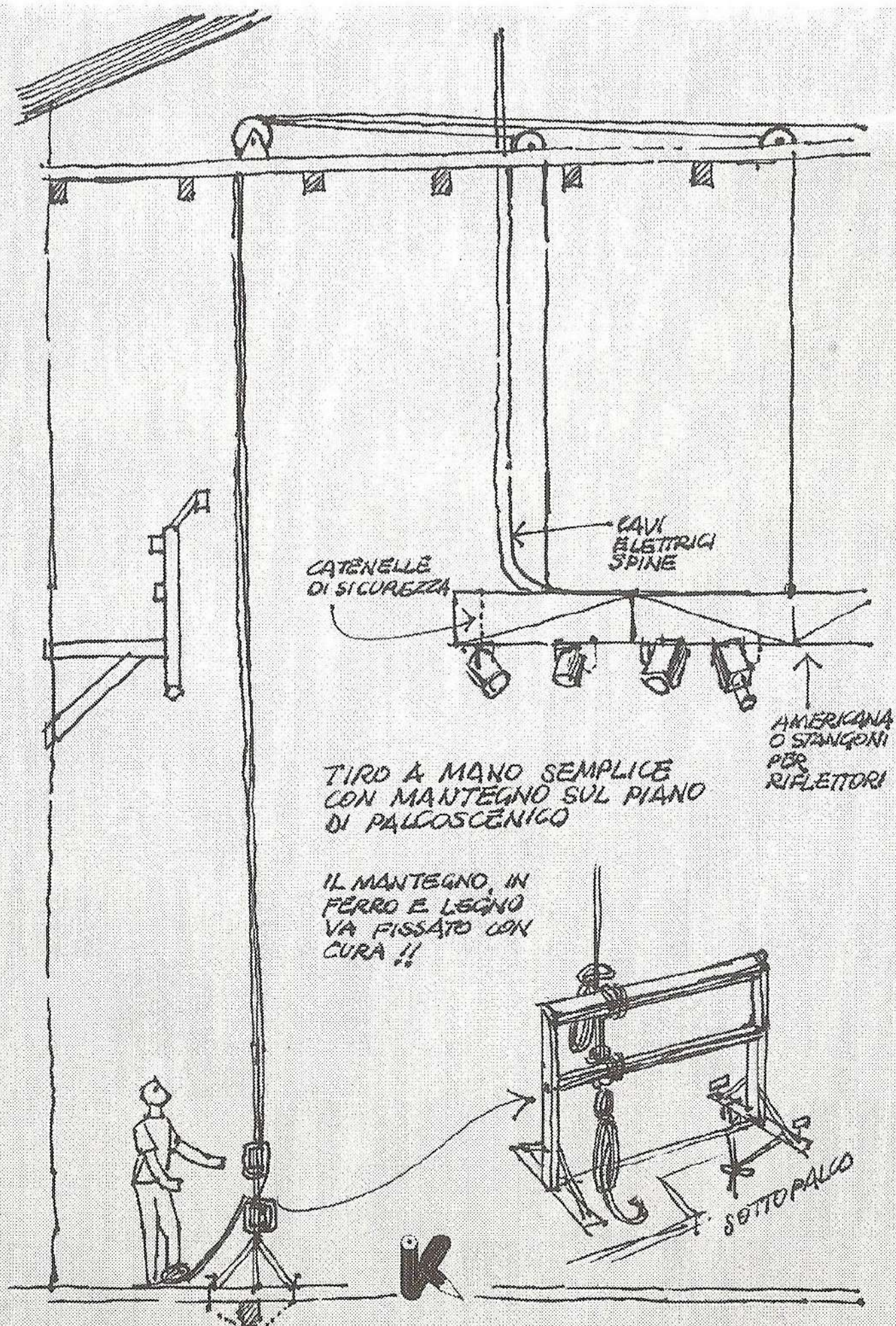

KOKI FREGNI/SCENOGRARO/MODENA

ALCUNI ESEMPI DI STANGONI  
IMPROVVISATI O DI DOTAZIONE

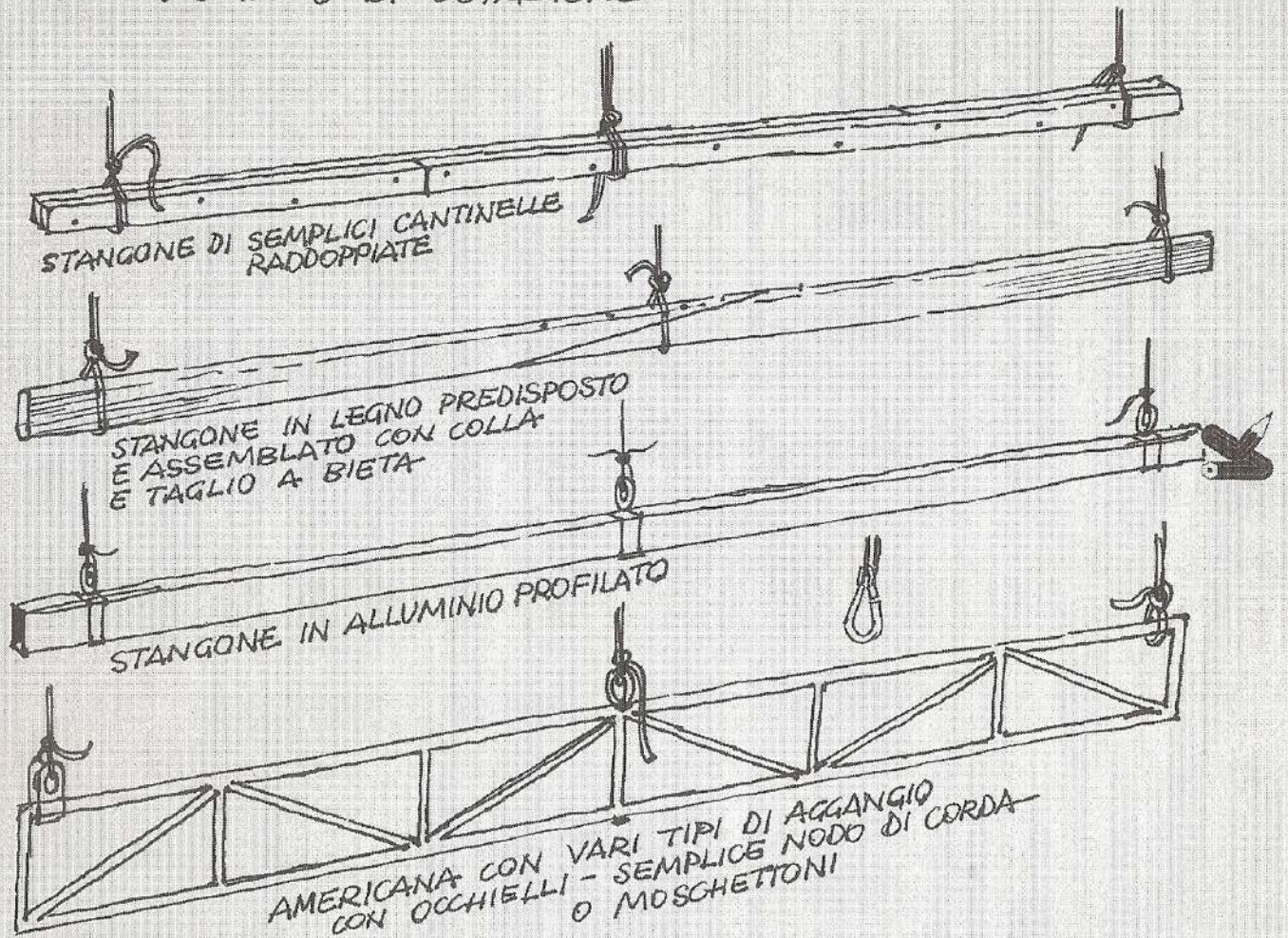

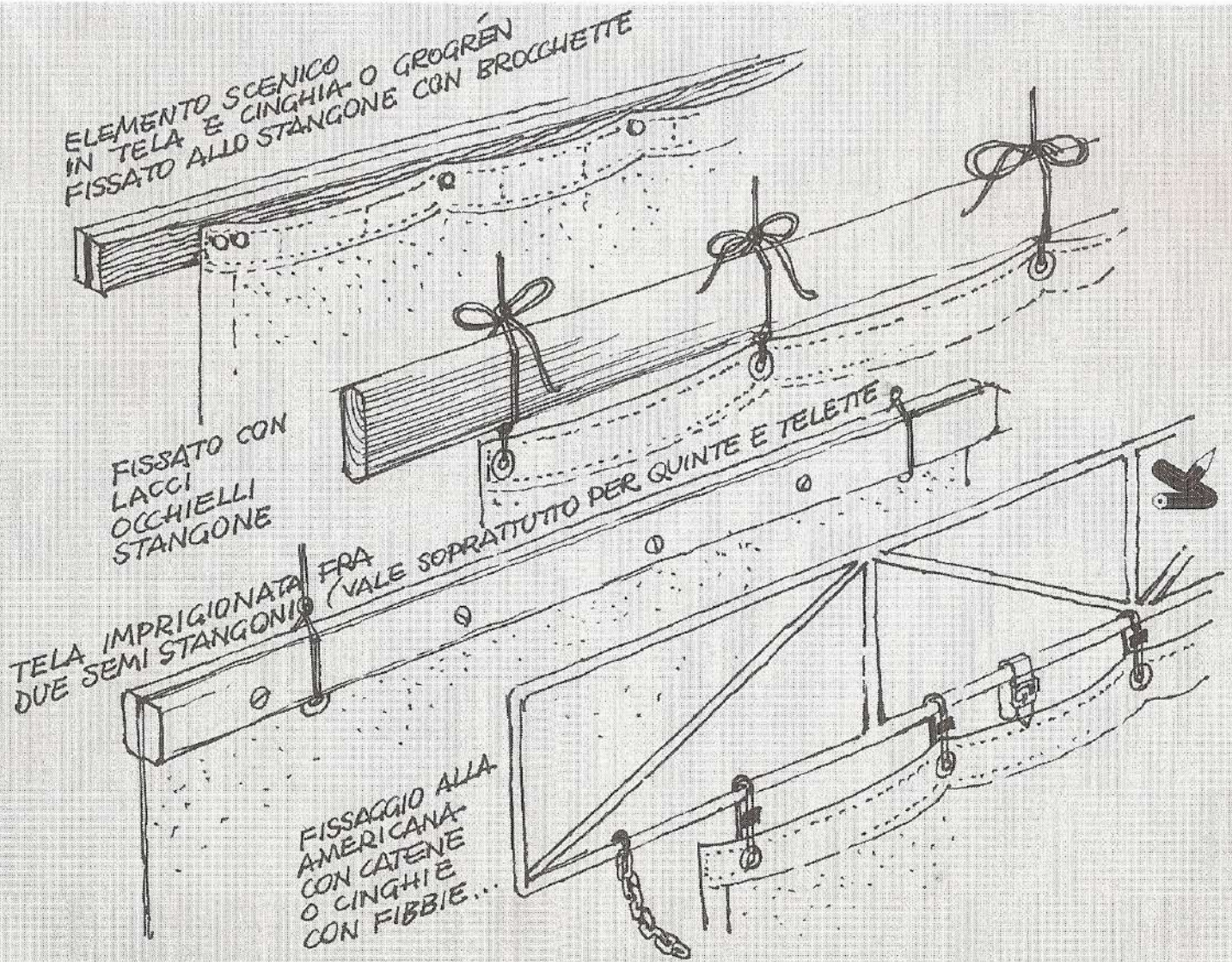

Tav. 13

PANORAMA IN TELA  
 AVVOLGIBILE SU RULLO  
 A LATO DEL BOCCASCENA  
 (IN DOTAZIONE A POCCHI  
 TEATRI PERCHE'  
 RIMOSI NEGLI ANNI '70)

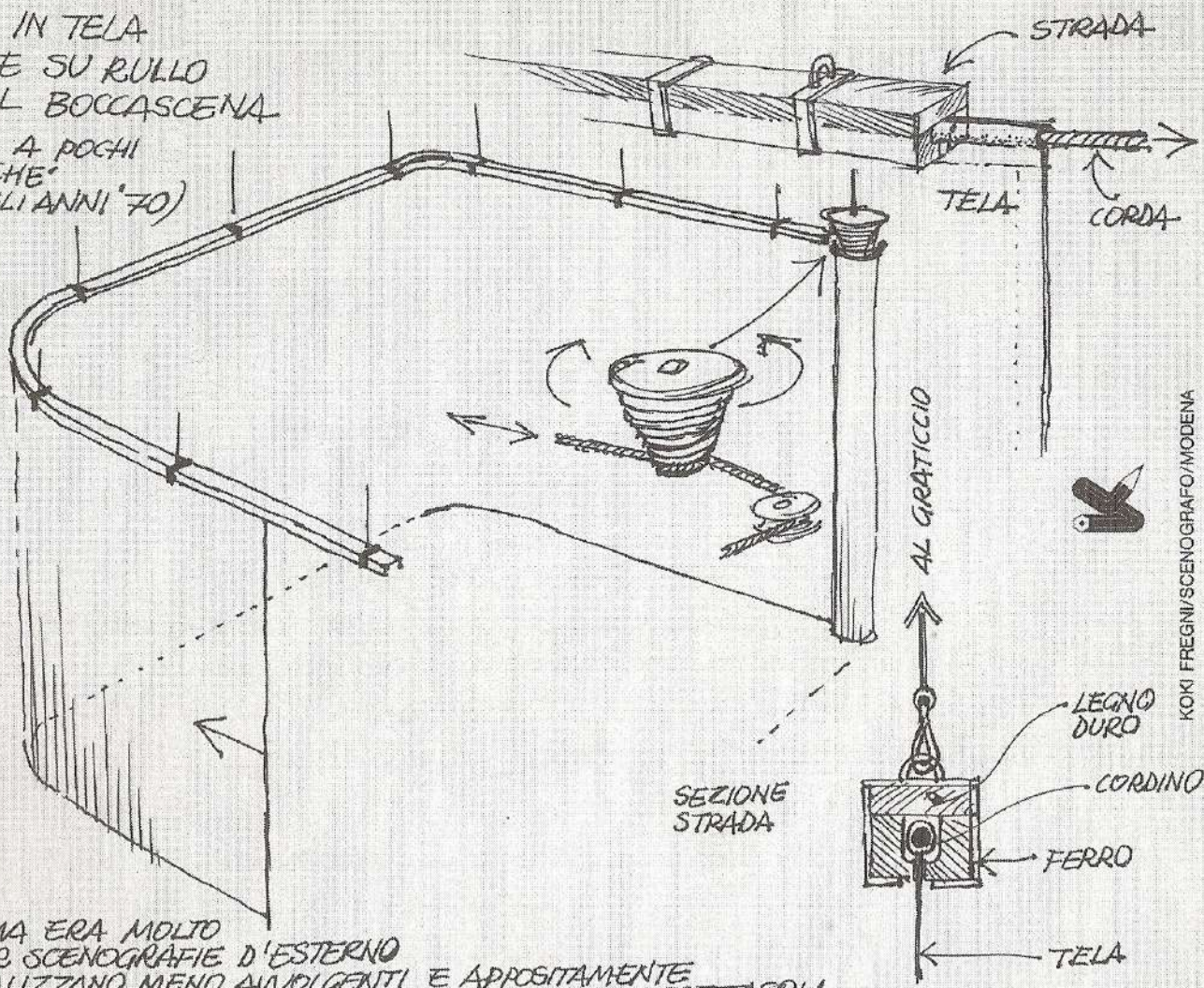

IL PANORAMA ERA MOLTO  
 INDICATO PER SCENOGRAFIE D'ESTERNO  
 OGGI SI REALIZZANO MENO AVVOLGENTI E APPPOSITAMENTE  
 PER SINGOLI SPETTACOLI

KOKI FREGNI/SCENOGRAFO/MODENA

Tav. 14

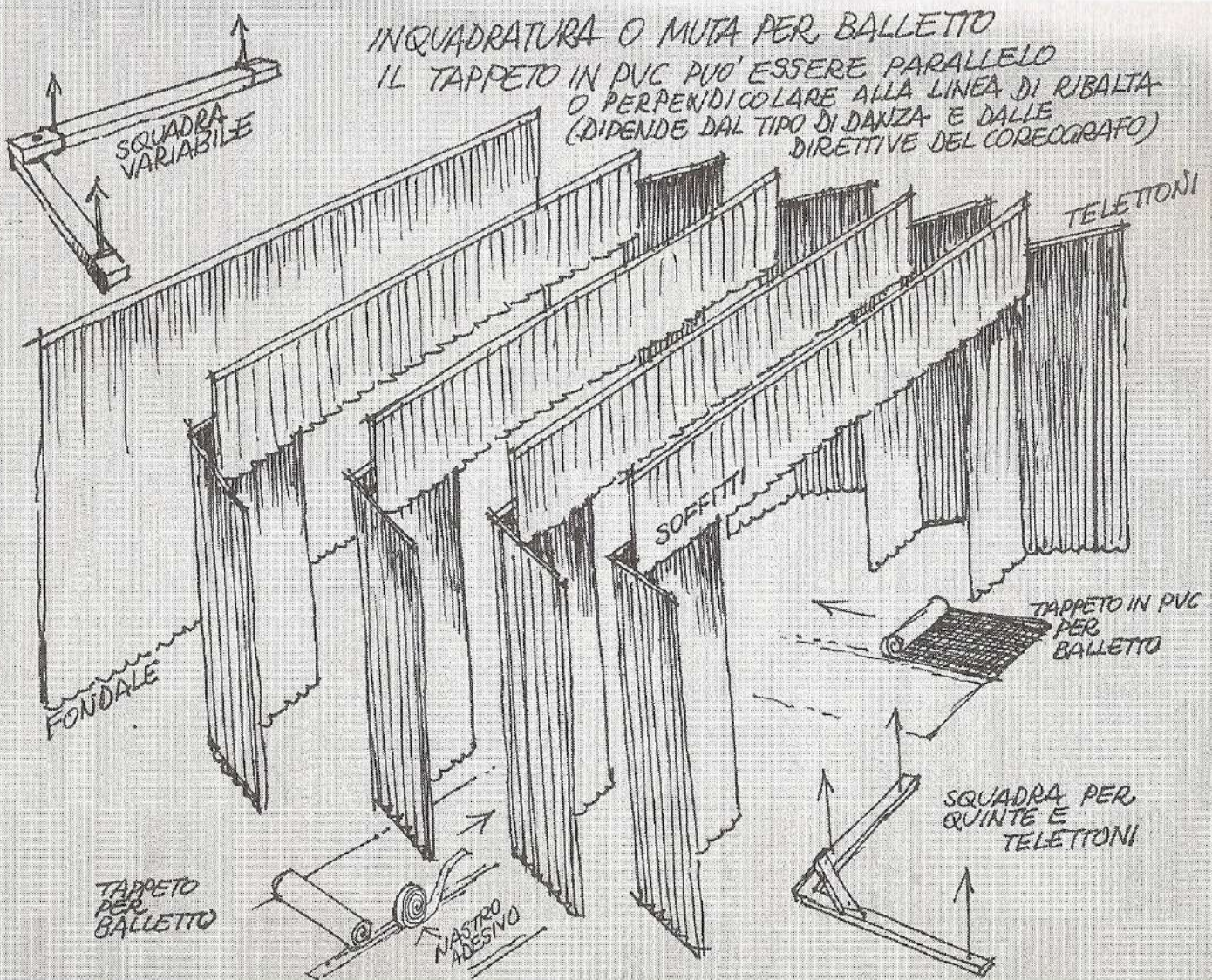

Tav. 15

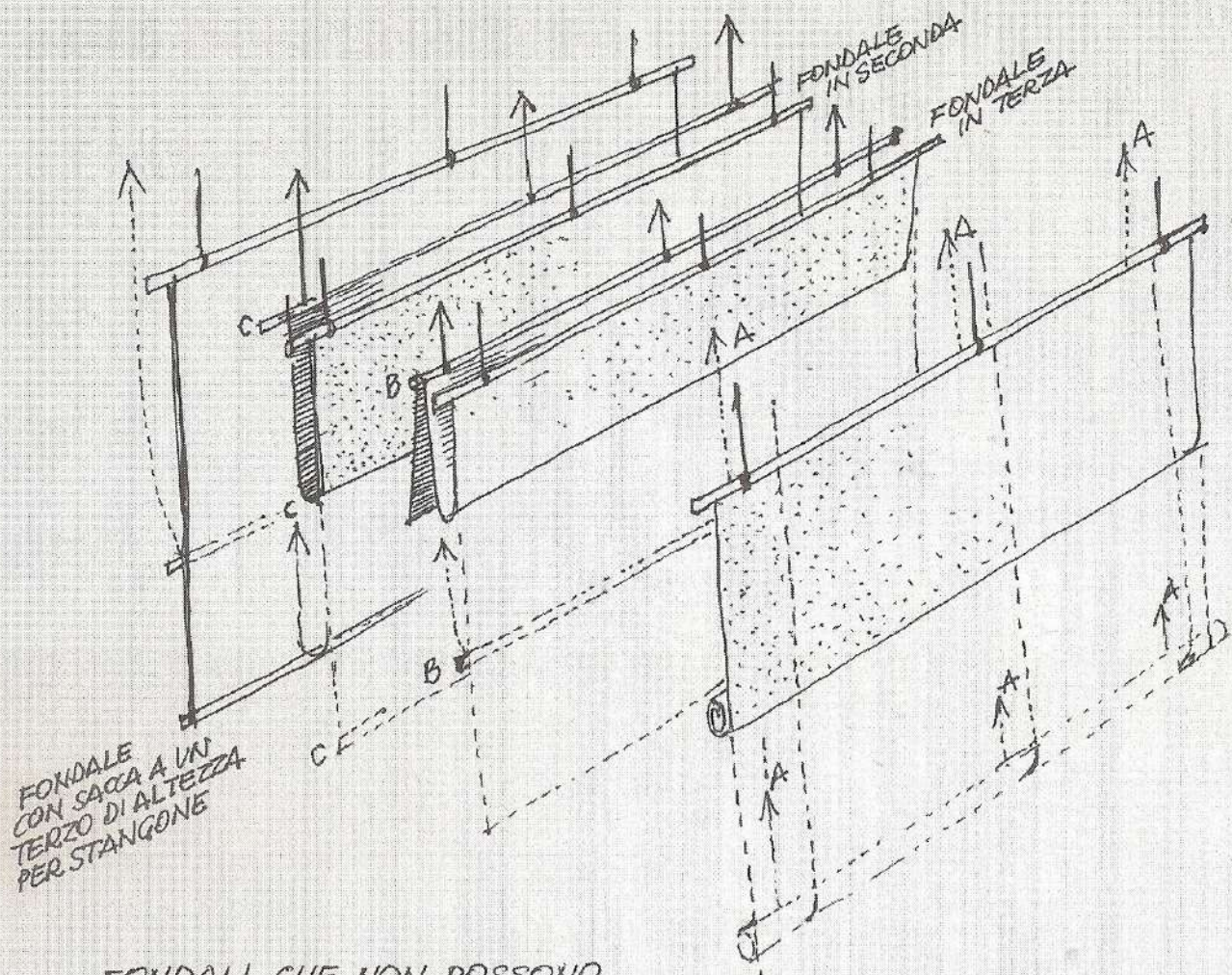

ALLA BURATTINA  
IL FONDALE O  
SIPARIETTO  
SI ARROTOLA  
TIRANDO "A" II  
I CORDINI "A" II

FONDALE  
CON SACCA A UN  
TERZO DI ALTEZZA  
PER STANGONE

FONDALI CHE NON POSSONO  
SALIRE IN PRIMA (TIRATI AL GRATICCIO SINO ALLA SCOMPARSA)  
QUINDI "ACCORCIATI" IN QUESTI DIFFERENTI MODI



Tav. 16



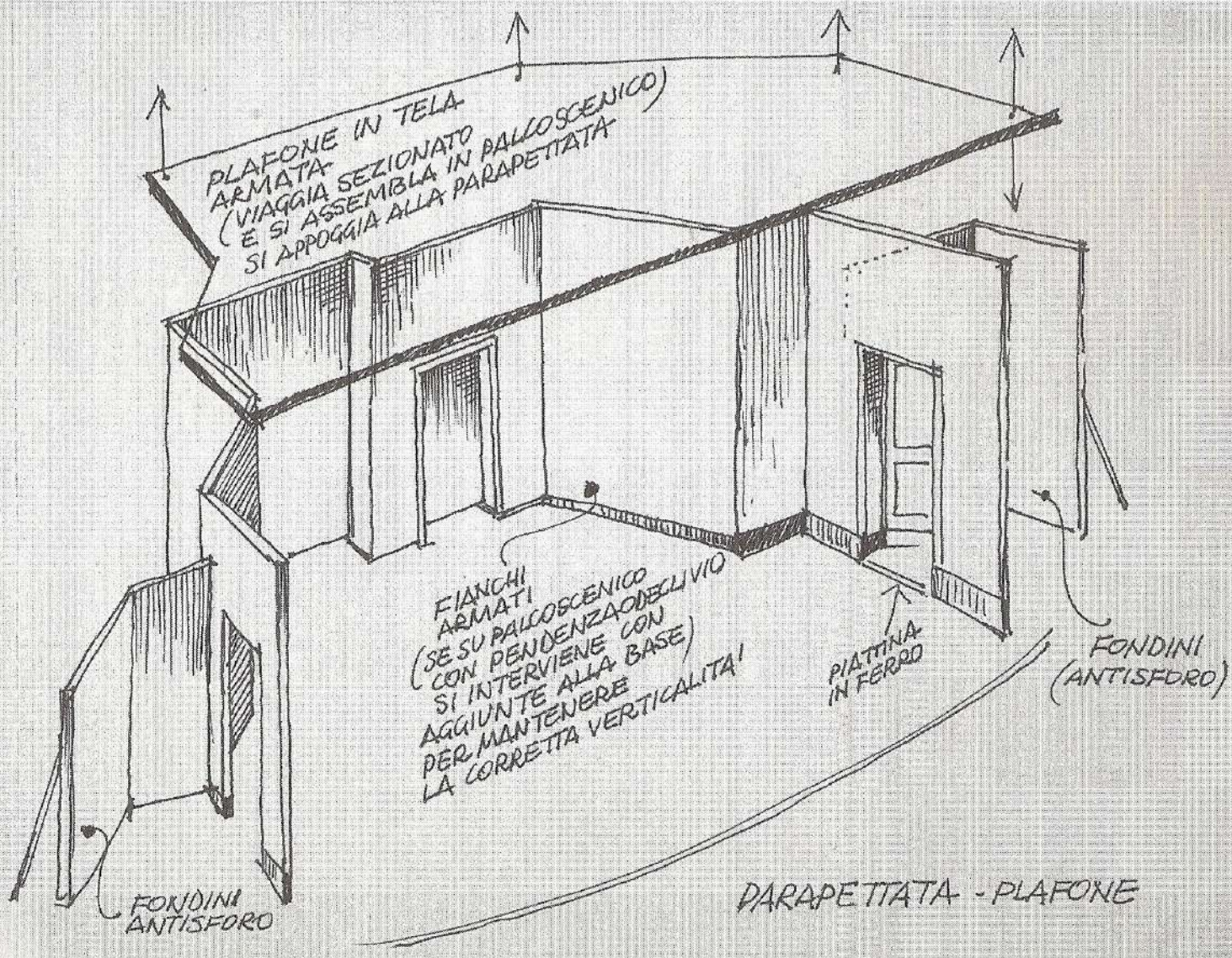

Tav. 17

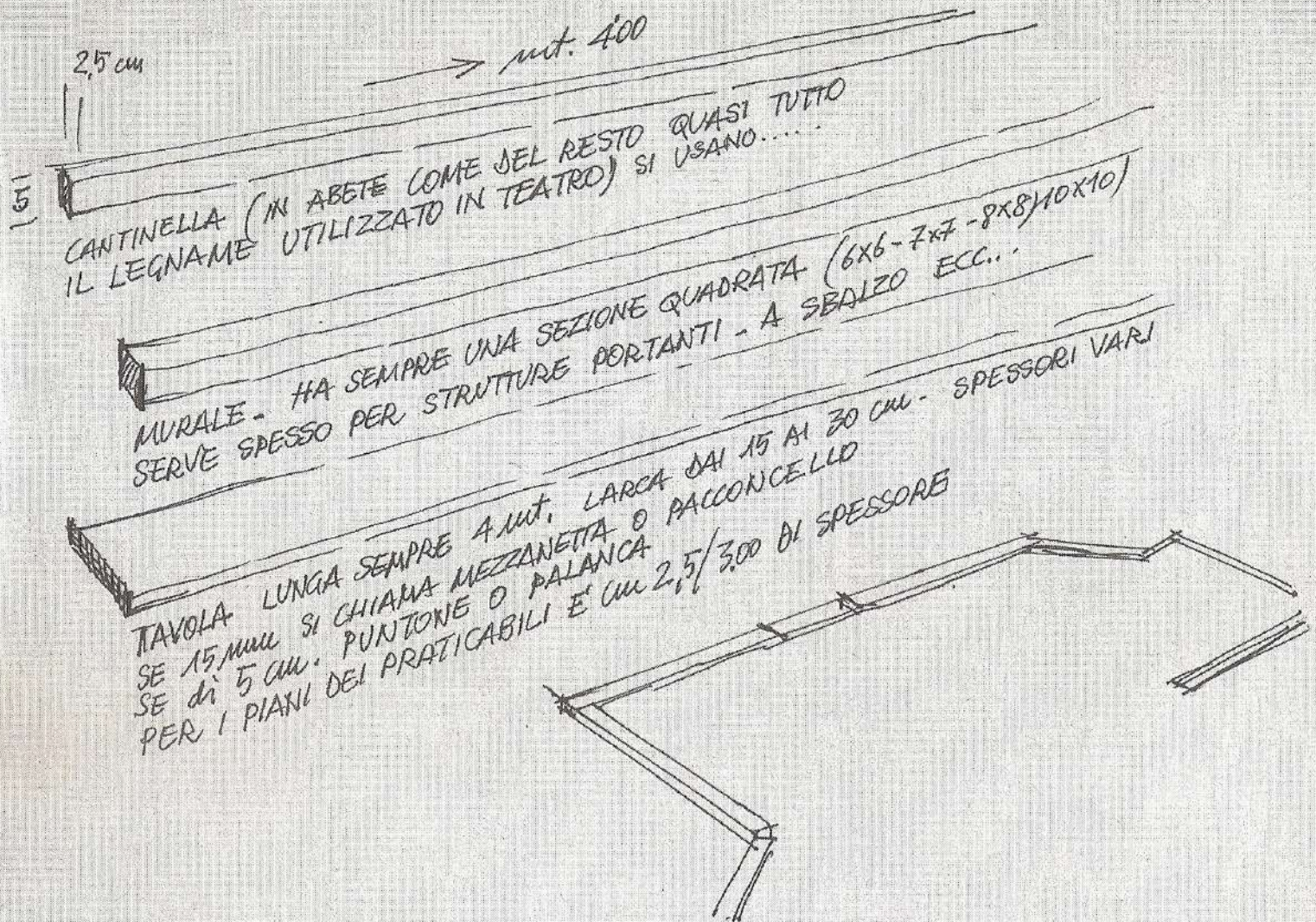

Tav. 18

- 1 CAVALLA (A FIRENZE "CAPRA")
- 2 AMERICANA
- 3 PIANO
- 4 NOTTOLE

IN QUESTO CASO LA DIMENSIONE  
E' DI CM 100 X 200 X 80 DI ALTEZZA  
E COMPOSTO DA 3 CAVALLE  
2 AMERICANE 1 PIANO

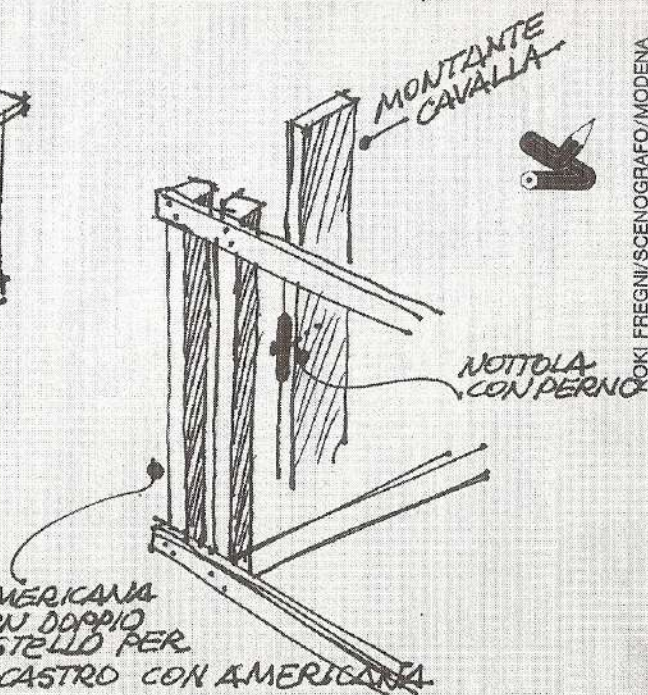
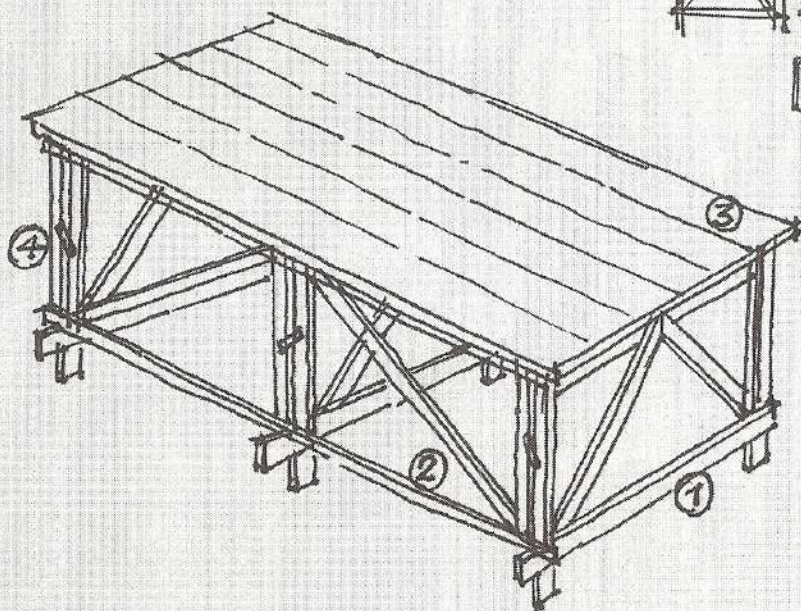
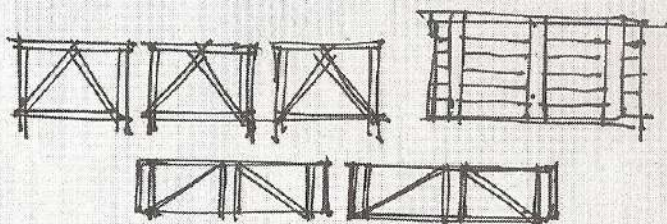

PRATICABILE SMONTABILE

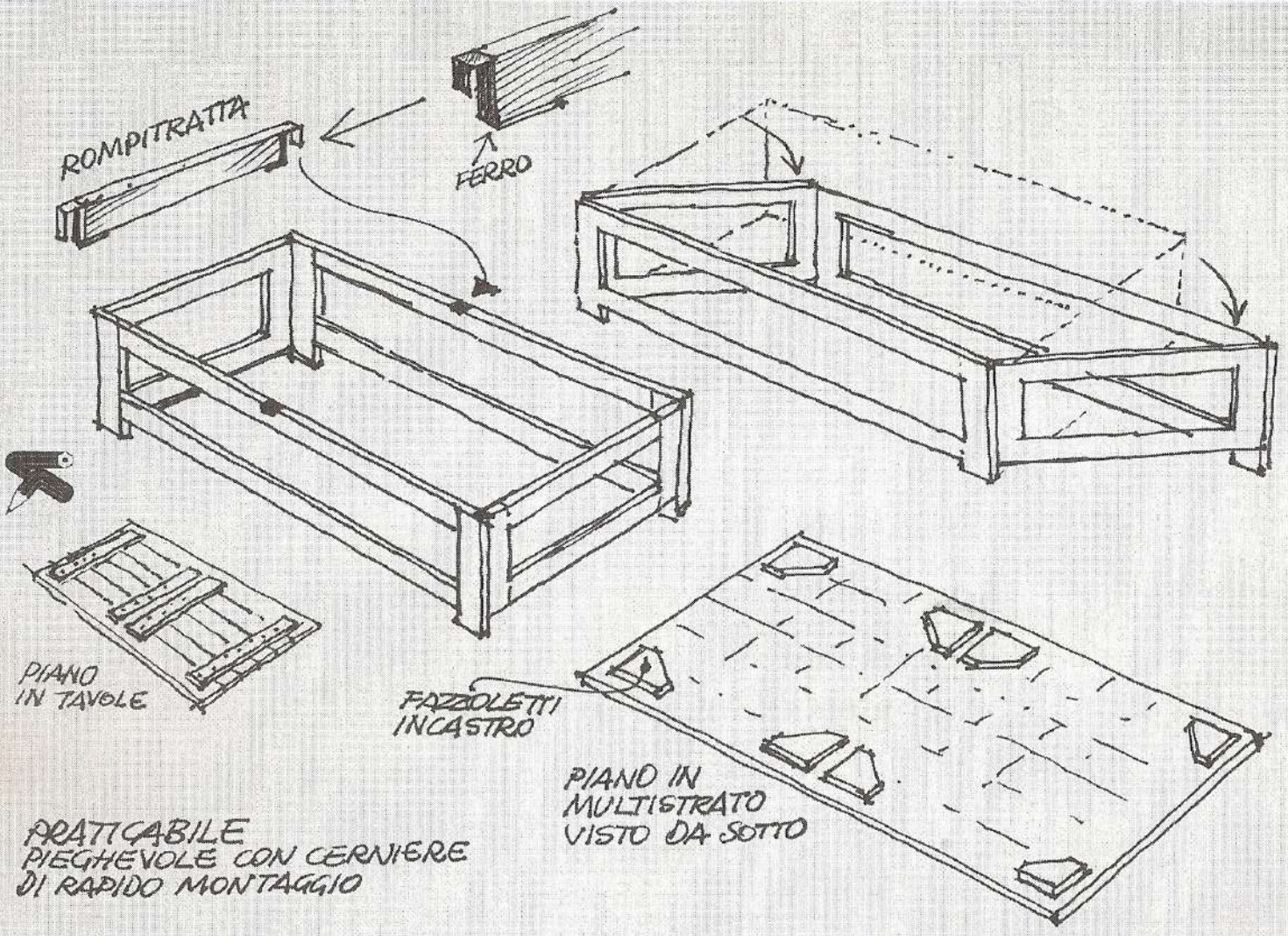

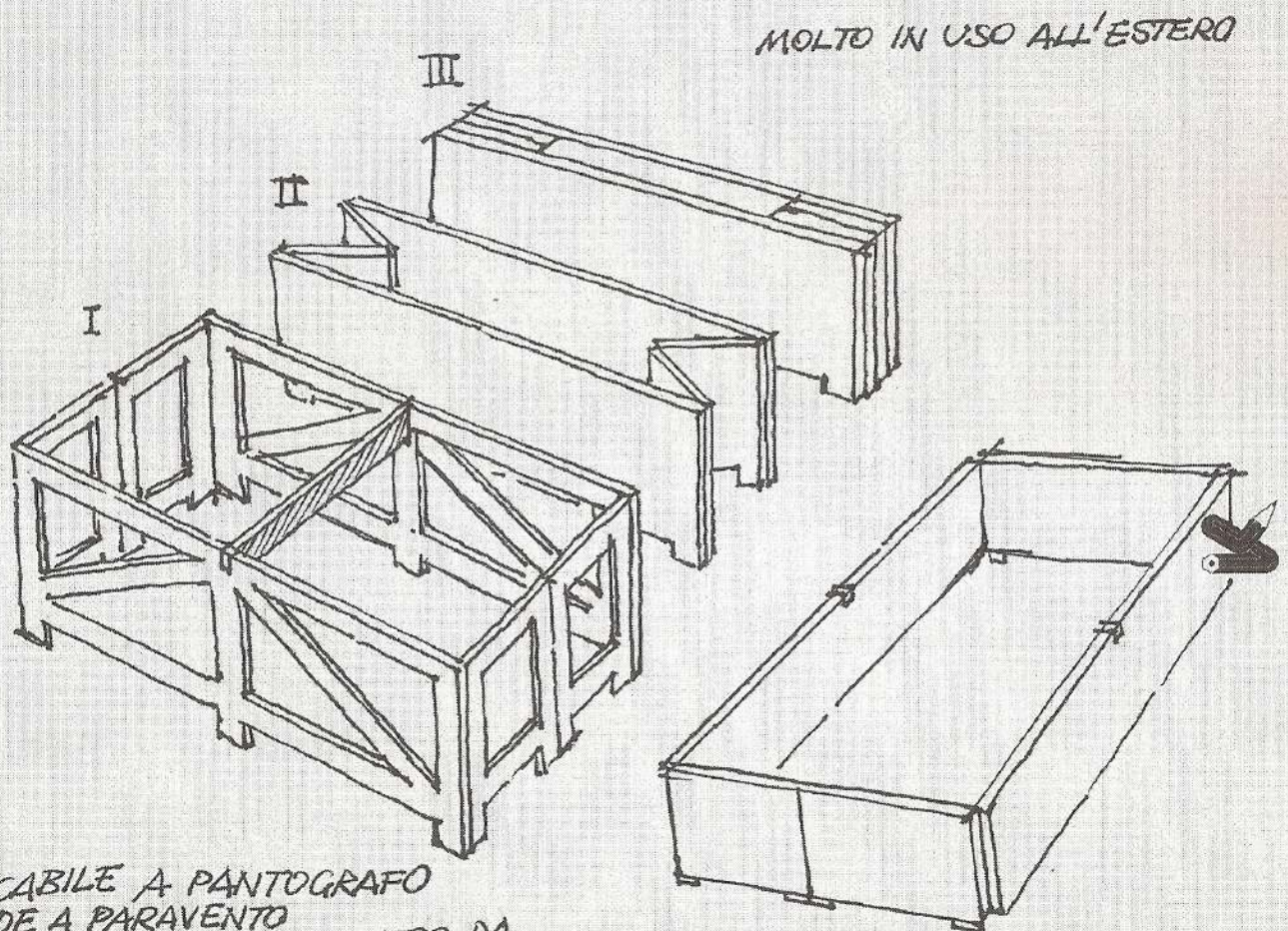

MOLTO IN USO ALL'ESTERO

PRATICABILE A PANTOGRAFO  
 SI CHIUDE A PARAVENTO  
 IL PIANO - SOSTENUTO AL CENTRO DA  
 UN ROMBITRATTA - LO TIENE  
 PERFETTAMENTE IN SQUADRO

SI PRESTA MOLTO PER  
 ALTEZZE RIDOTTE...  
 E' DI FACILE STIVAGGIO

KOKI FREGNI/SCENOGRAFO/MODENA

Tav. 21

SCHIZZO INDICATIVO  
DI PRATICABILE A PANTOGRAFO  
(PRODOTTO IN GERMANIA)

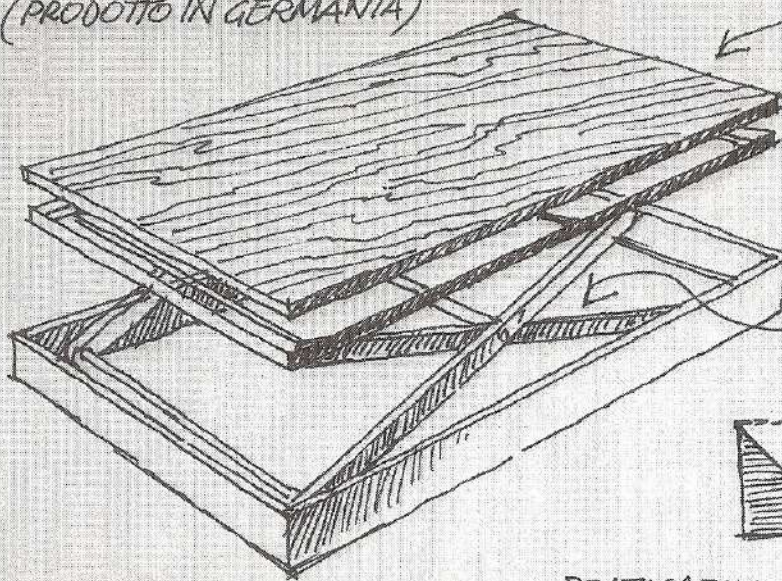

PIANO BIFACCIALE  
(DA UN LATO LEGNO  
DALL'ALTRA PLASTICA)

TELAIO CON FERRO A "L"  
PER CONTENERE  
IL PIANO

ELEMENTO A PANTOGRAFO  
PER SOLLEVAMENTO PIANO  
ALL'ALTEZZA DESIDERATA  
ENTRO GLI OTTANTA CM.

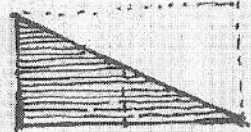

PRATICABILI AD ANGOLO RETTO (NICCHIO)  
COMPONIBILI



mit 1x1

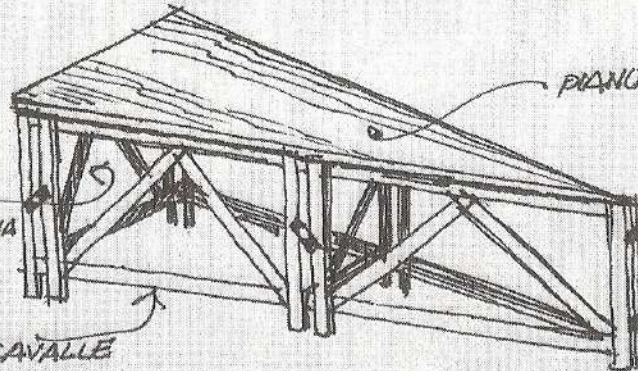
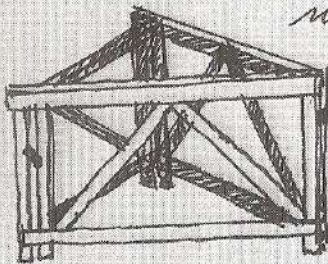

mit 2x1

AMERICANA

CAVALLE

PIANO

CERNIERE

SCIVOLI O CONTROSCIVOLI  
 AGEVOLMENTE PRATICABILI SE NON SUPERANO  
 IL 10/15 % AL mt. COMPRESO IL DECLIVIO  
 DEL PALCOSCENICO

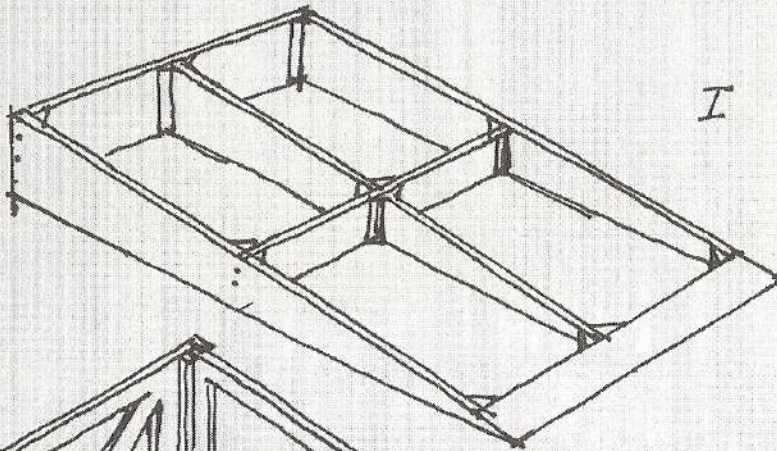

I SCIVOLO COMPATTO  
 (SE NON SUPERA II  
 1.20/25 CM E' MEGLIO  
 FARE UN BLOCCO UNICO  
 COMPRESO IL PIANO

SI REALIZZA NORMALMENTE  
 IN COMPENSATO O  
 MULTISTRATO DI  
 20 MM. DI SPESSORE

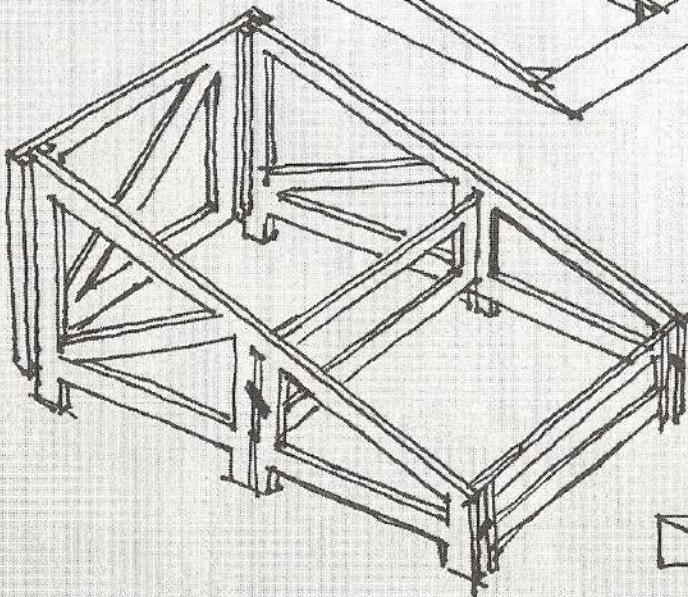

II SCIVOLO SMONTABILE  
 COSTRUITO COME I PRATICABILI  
 CON CAVALLE E  
 AMERICANE.

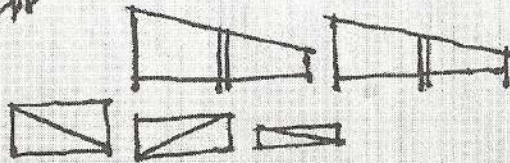

PRATICABILE CON STRUTTURA  
PORTANTE IN ACCIAIO  
E PIANO IN LEGNO TRATTATO

SI PUO' PORTARE  
RAPIDAMENTE DA cm 15  
A 80/60/50/30 ecc...

E' COSTOSO MA, ALLA  
FINE, REDDITIZIO

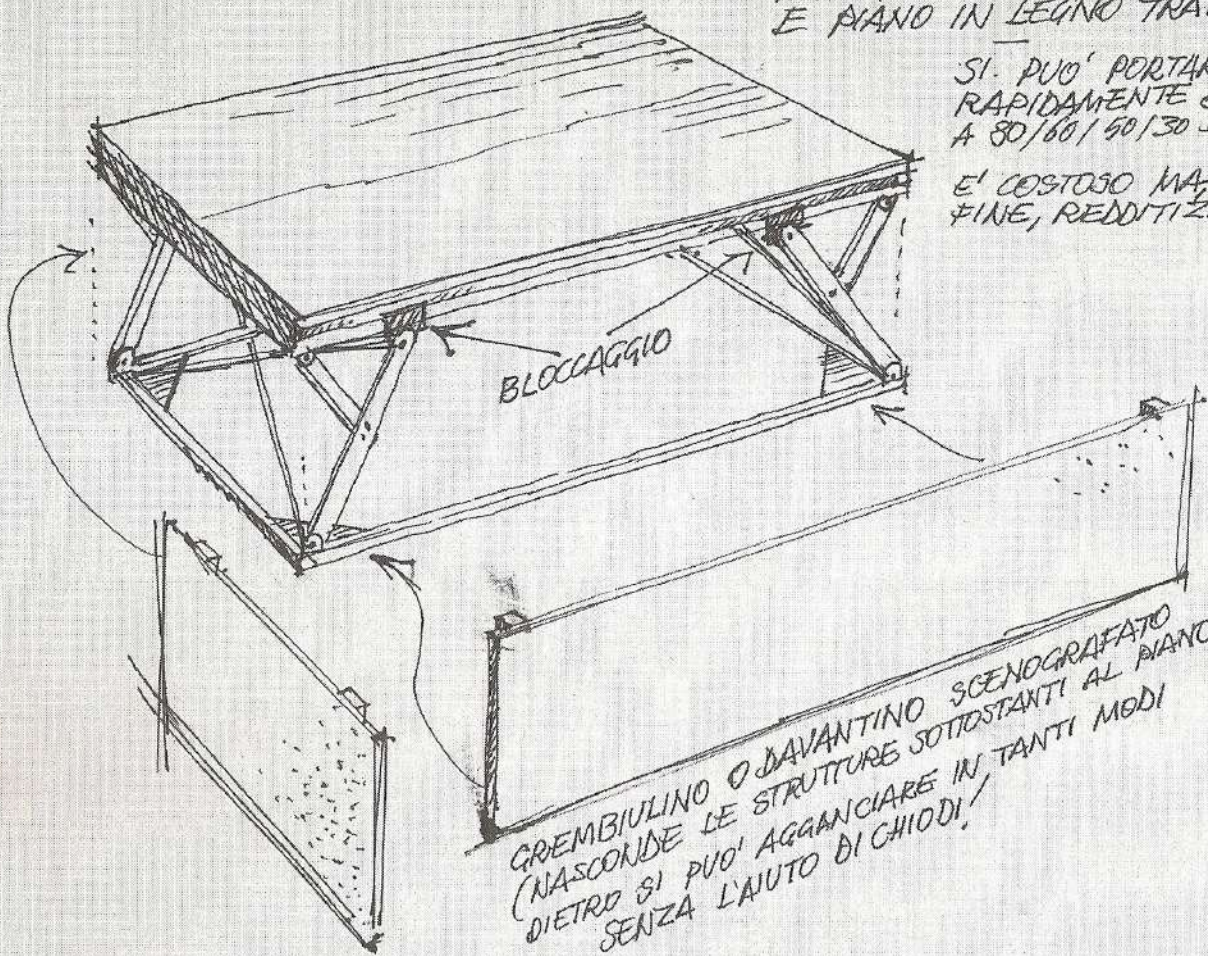

GREMBIULINO O DAVANTINO SCENOGRAFATO  
(NASCONDE LE STRUTTURE SOTTOSTANTI AL PIANO  
DIETRO SI PUO' AGGANCIARE IN TANTI MODI  
SENZA L'AUTO DI CHIODI!)





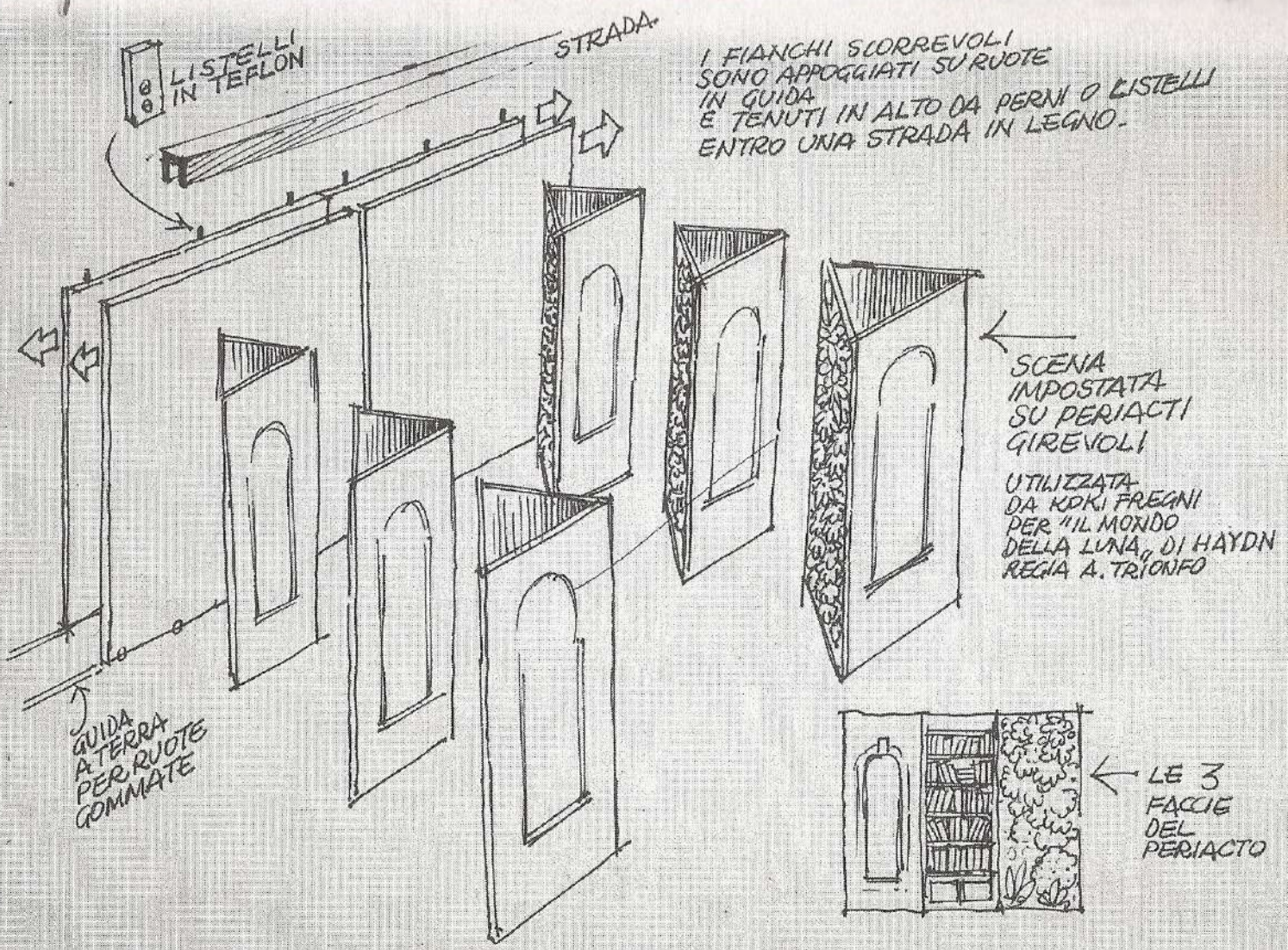

Tav. 25

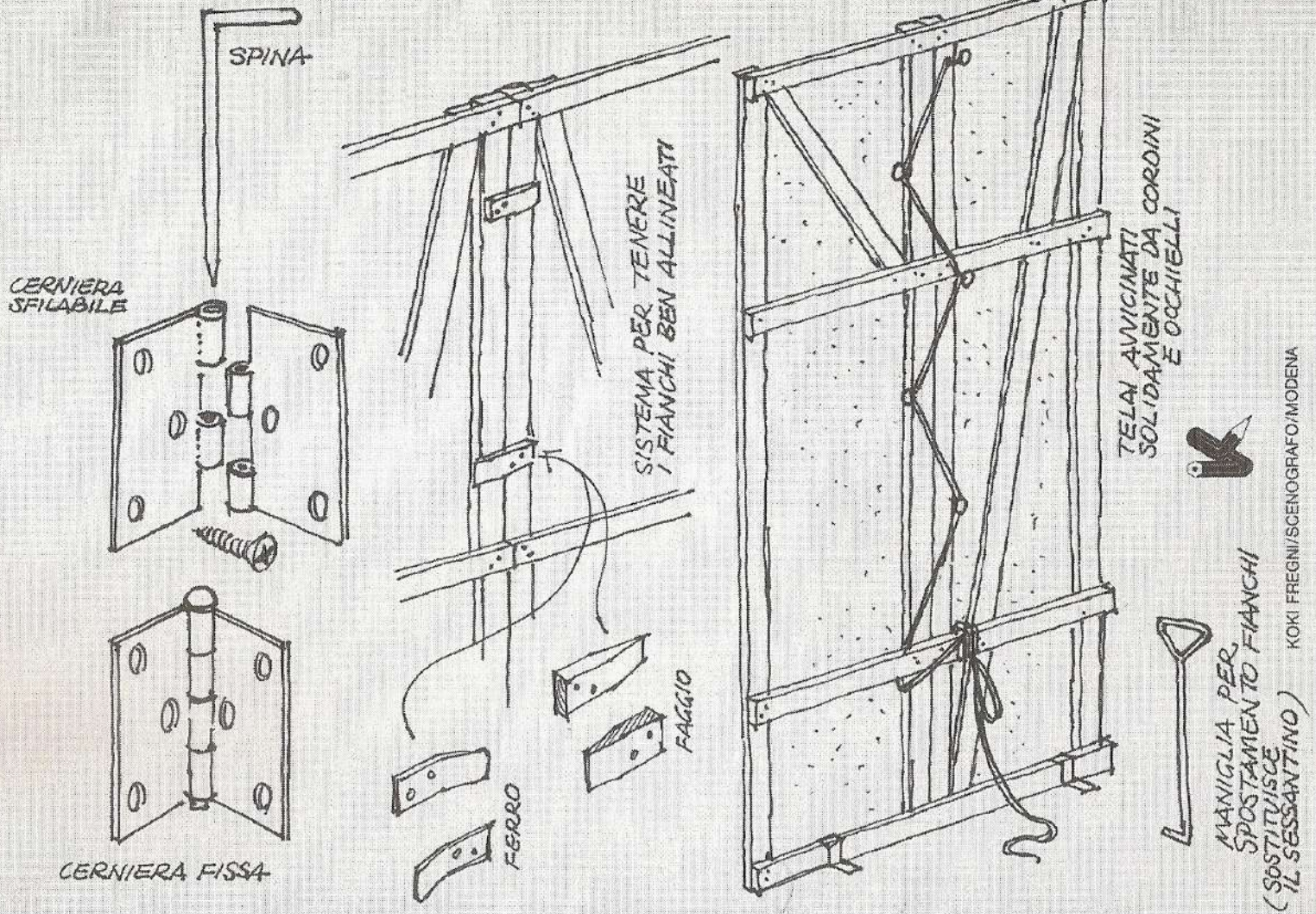

Tav. 26

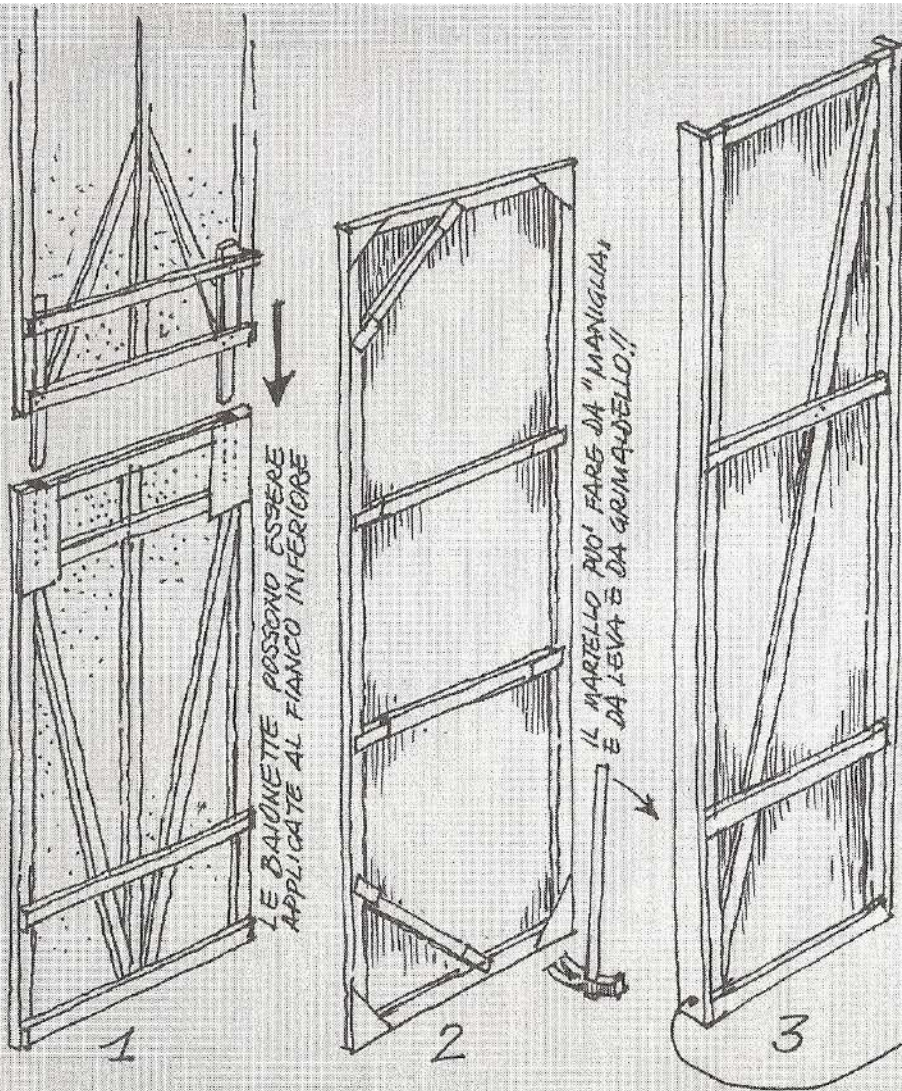

LE BAIONETTE POSSONO ESSERE APPLICATE AL FIANCO INFERIORE

IL MARTELLO PUO' FARE DA "MANIGLIA" E DA LEVA E DA GRINAGNELLO!!

1 FIANCO MOLTO ALTO PER TRASPORTO E STIVAGGIO - SI RICORRE AD INNESTO A BAIONETTA

2 SISTEMA DI REALIZZAZIONE FIANCHI IN AMERICA - DUE SQUADRETTI TRAVERSI E FAZZOLETTI DI COMPENSATO

3 QUANDO I TELAI SONO MOLTO ALTI SI RAFFORZANO CON CANTINELLE O MONTANTI DI MISURA PIU' CONSISTENTE AI LATI E IN COSTA

TELAJ ASSEMBLATI CON "FAZZOLETTI" DI COMPENSATO

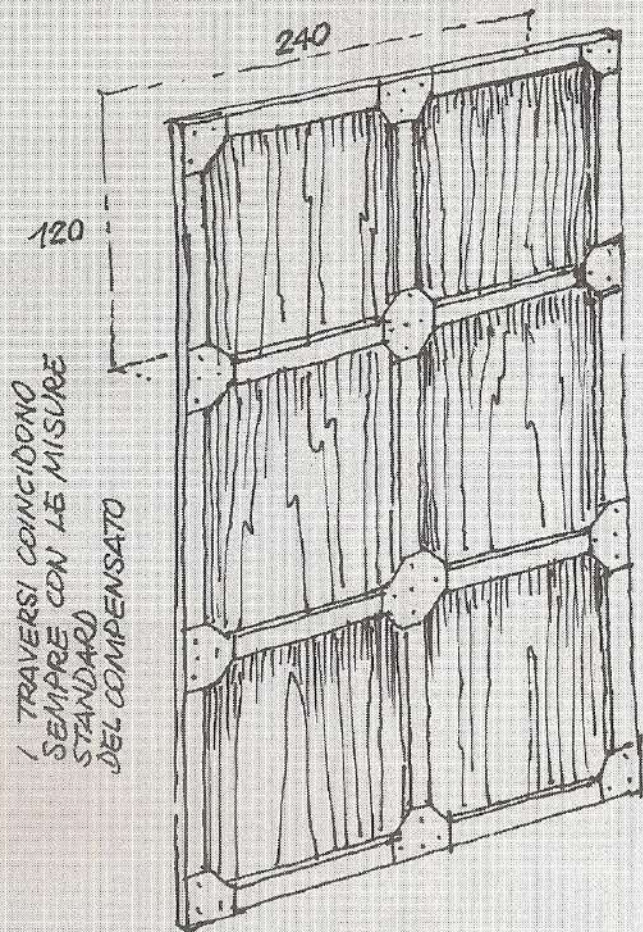

( TRAVERSI COINCIDONO  
SEMPRE CON LE MISURE  
STANDARD  
DEL COMPENSATO

FIANCO CON CANTINELLE  
E FAZZOLETTI E FOGLI DI  
COMPENSATO

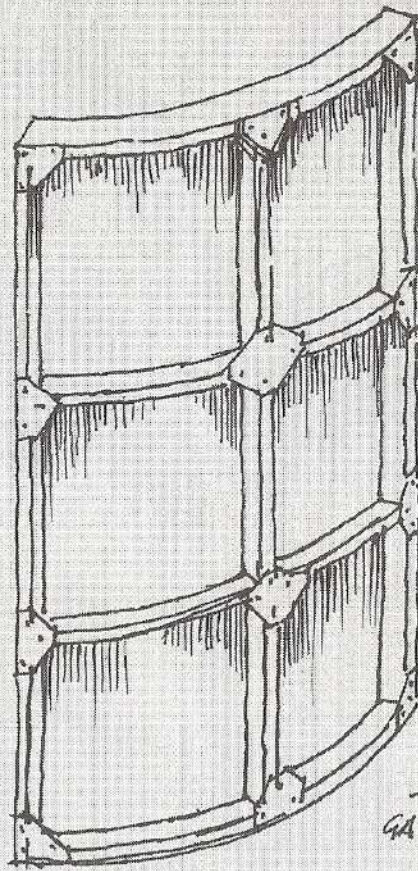

FIANCO CONVESSO  
CON CENTINE IN MULTISTRATO  
E FAZZOLETTI IN COMPENSATO

PICCOLO TELAI  
"TAMBURATO"  
BIFRONTALE

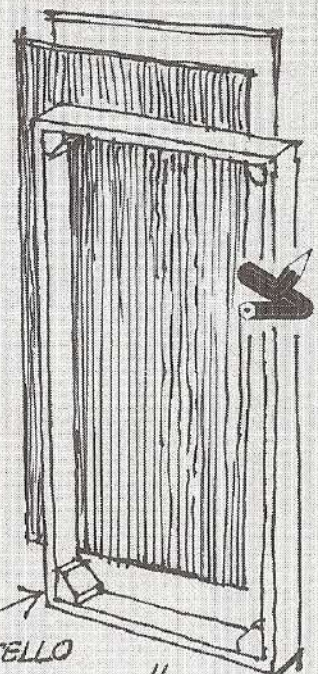

GATTELLO

IL  
TELAIO  
VIENE  
IMPRIGIONATO  
DA 2  
COMPENSATI

MONTAGGIO TELA SU FIANCHI

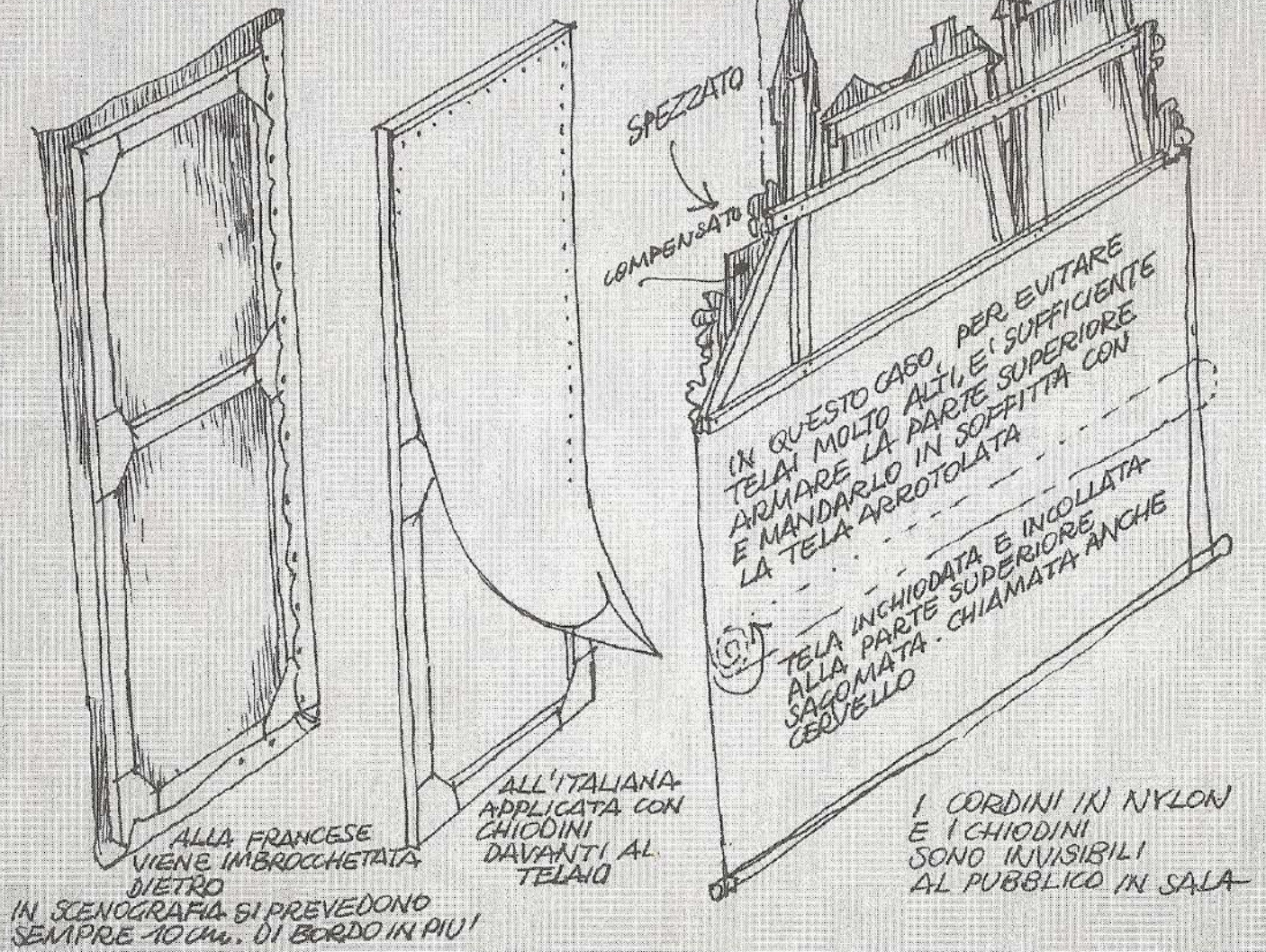

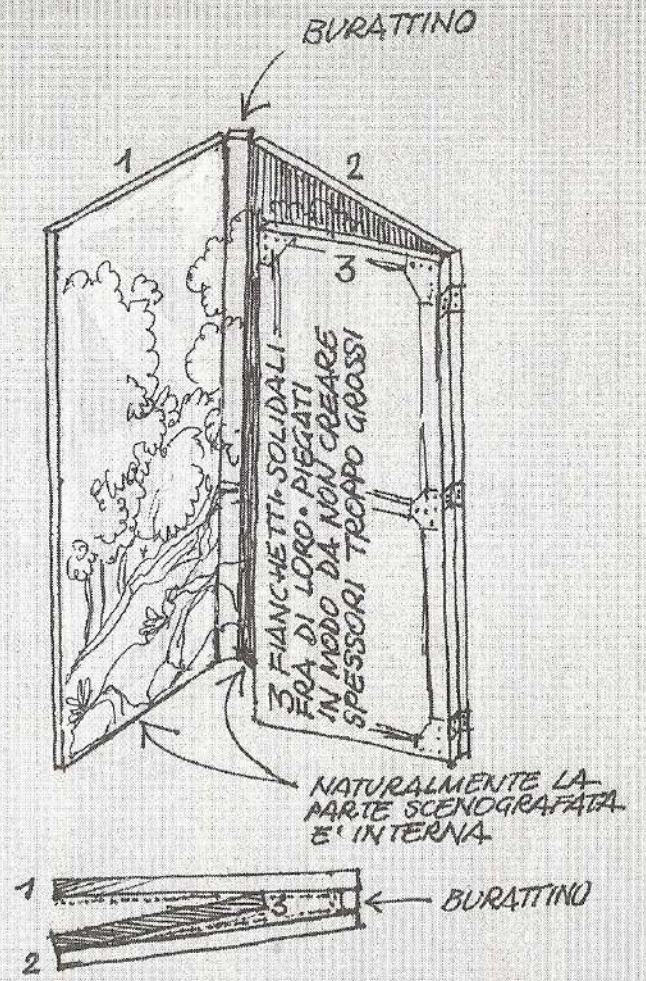
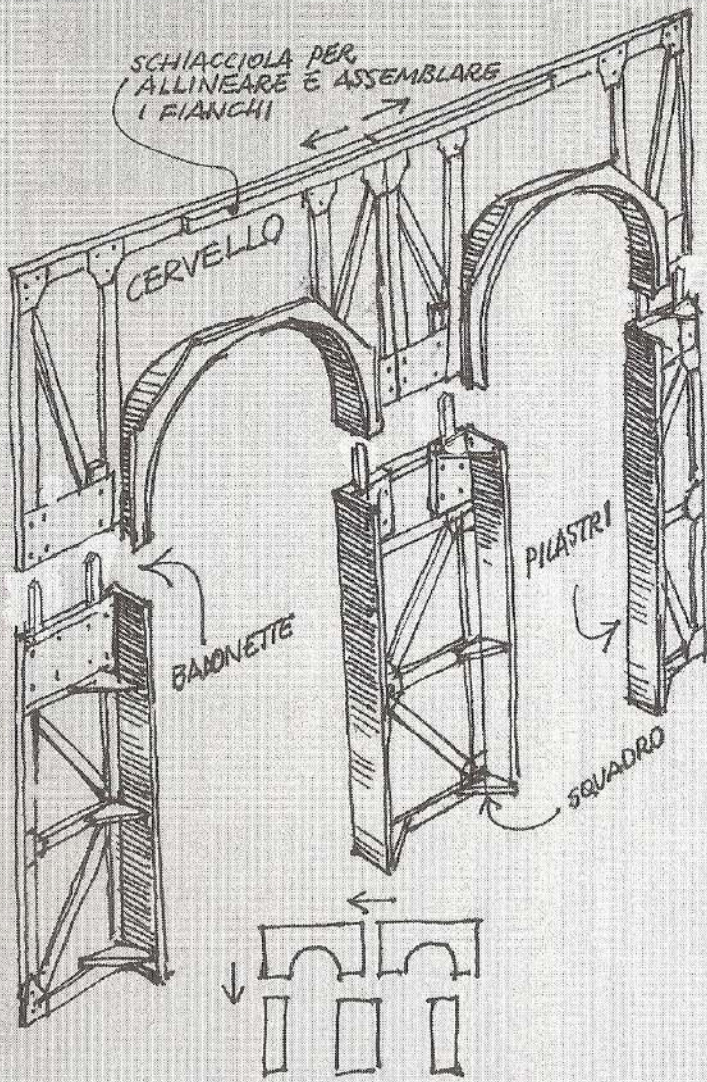

Tav. 30

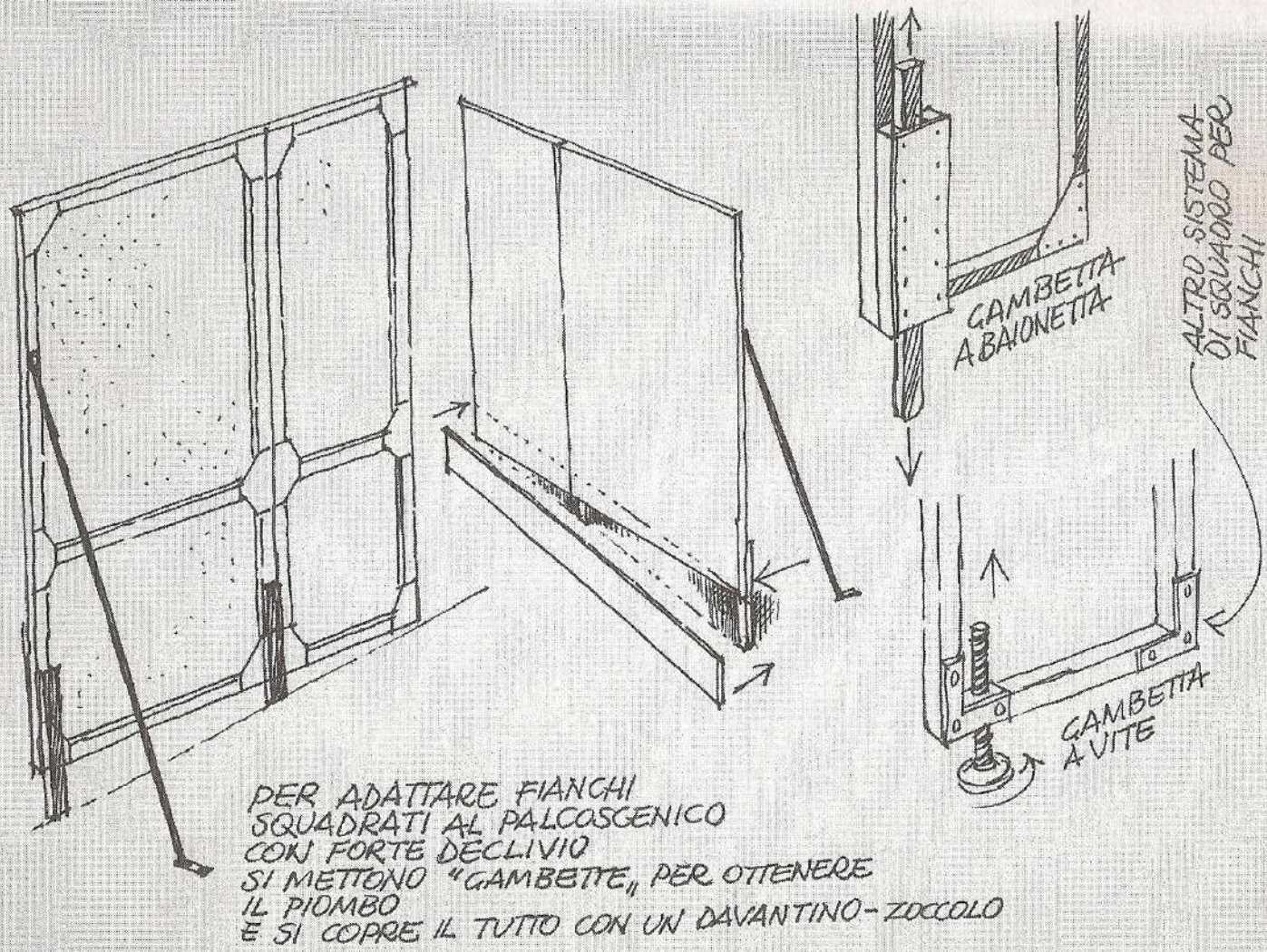

Tav. 31

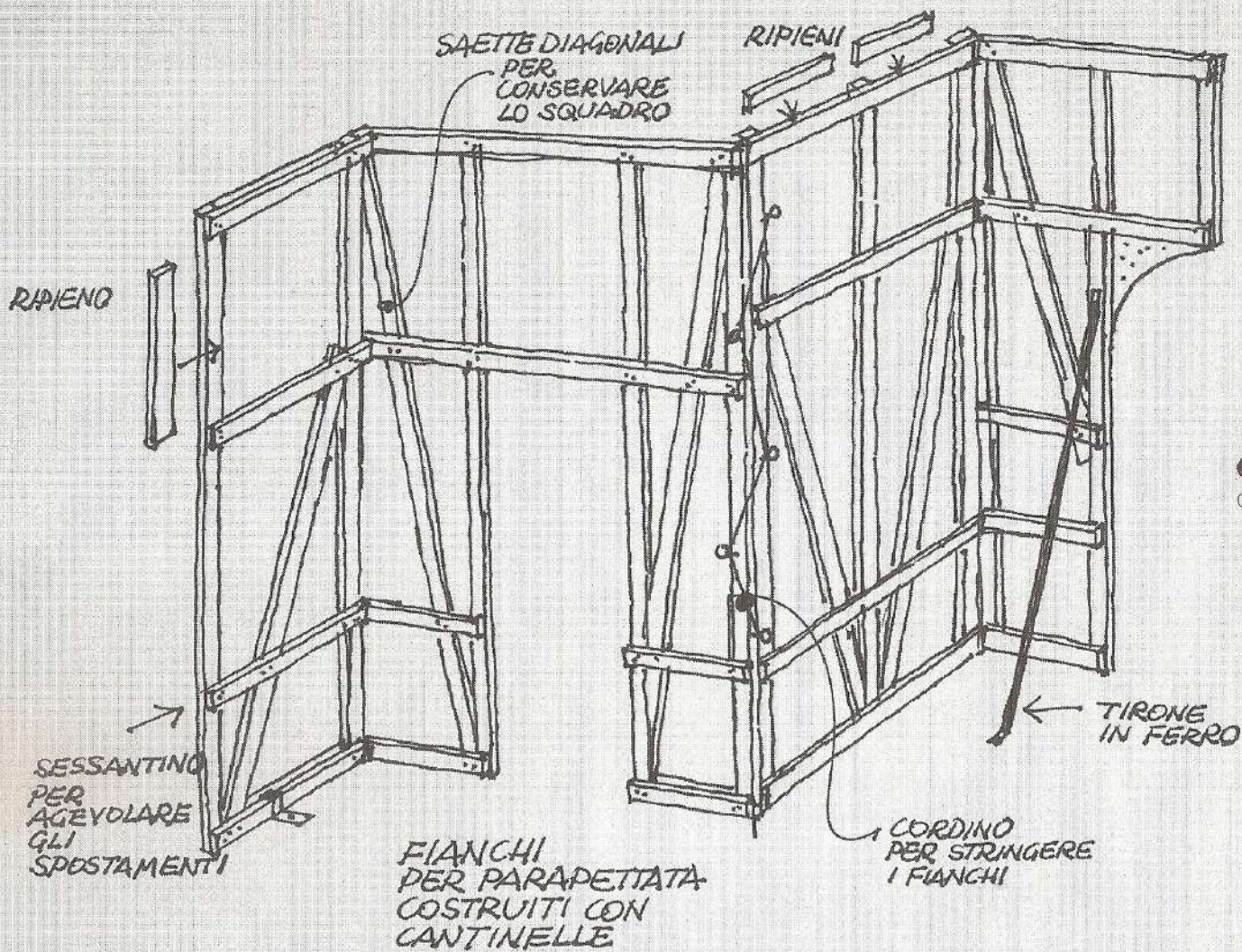

Tav. 32



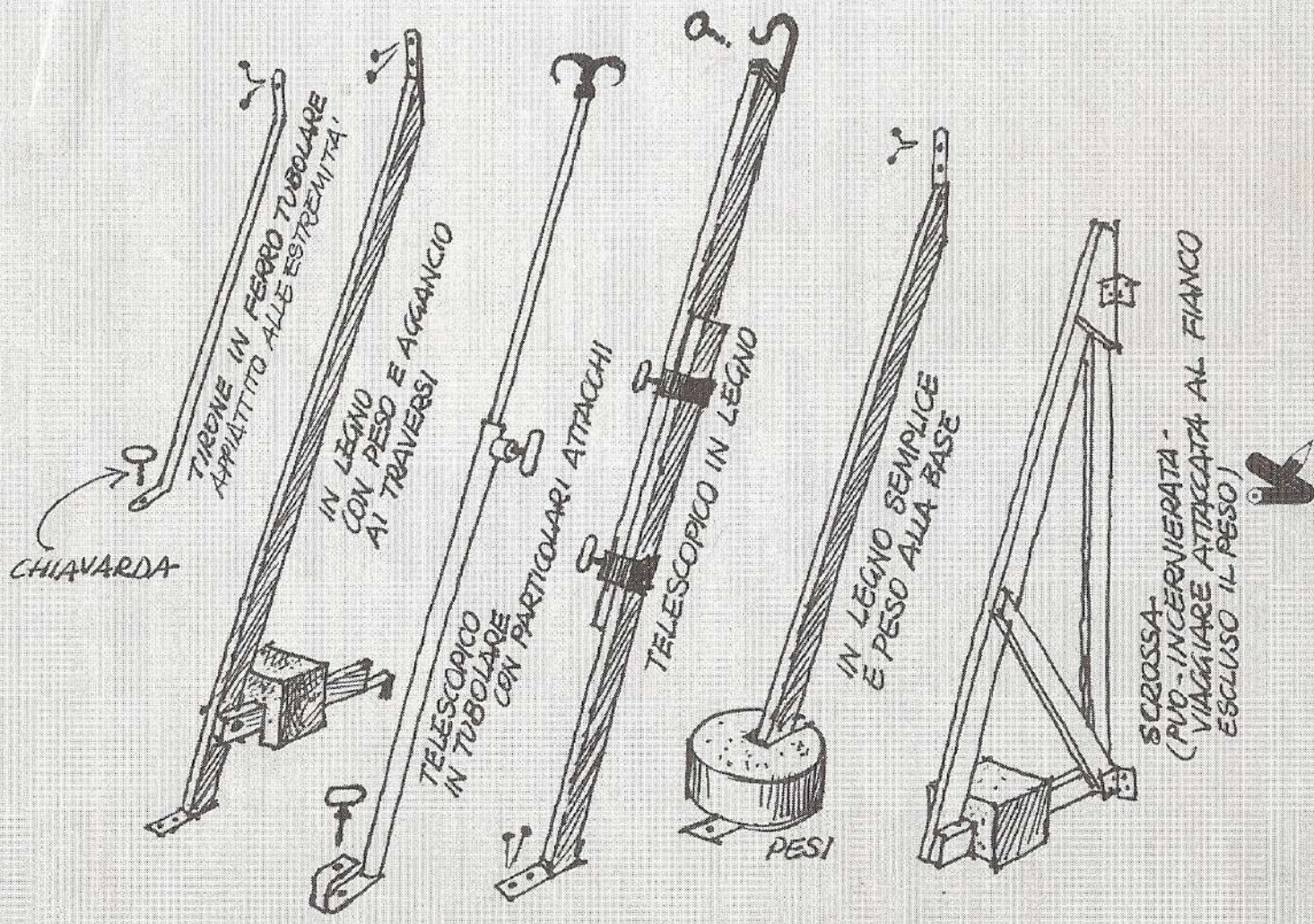

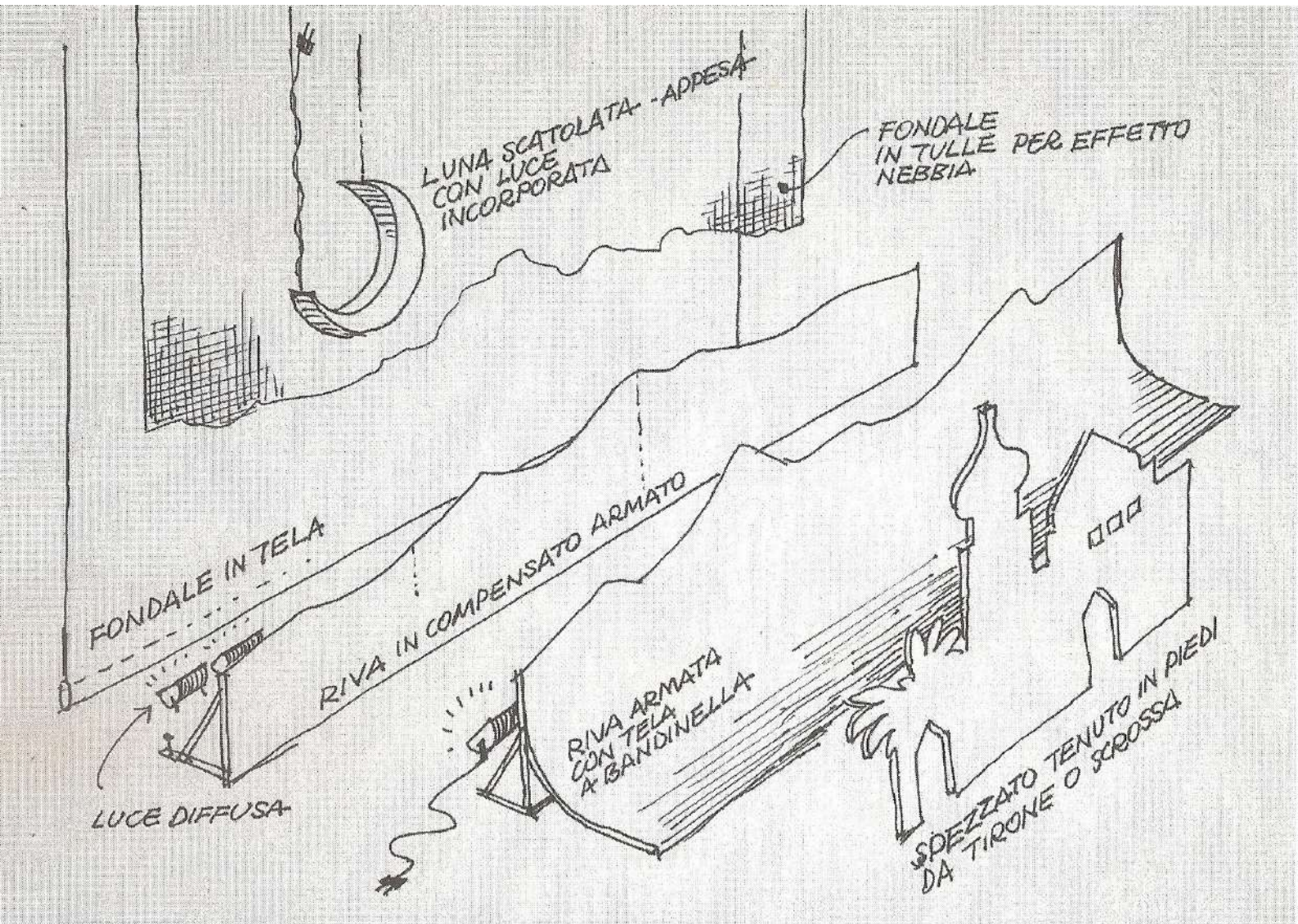

Tav. 34

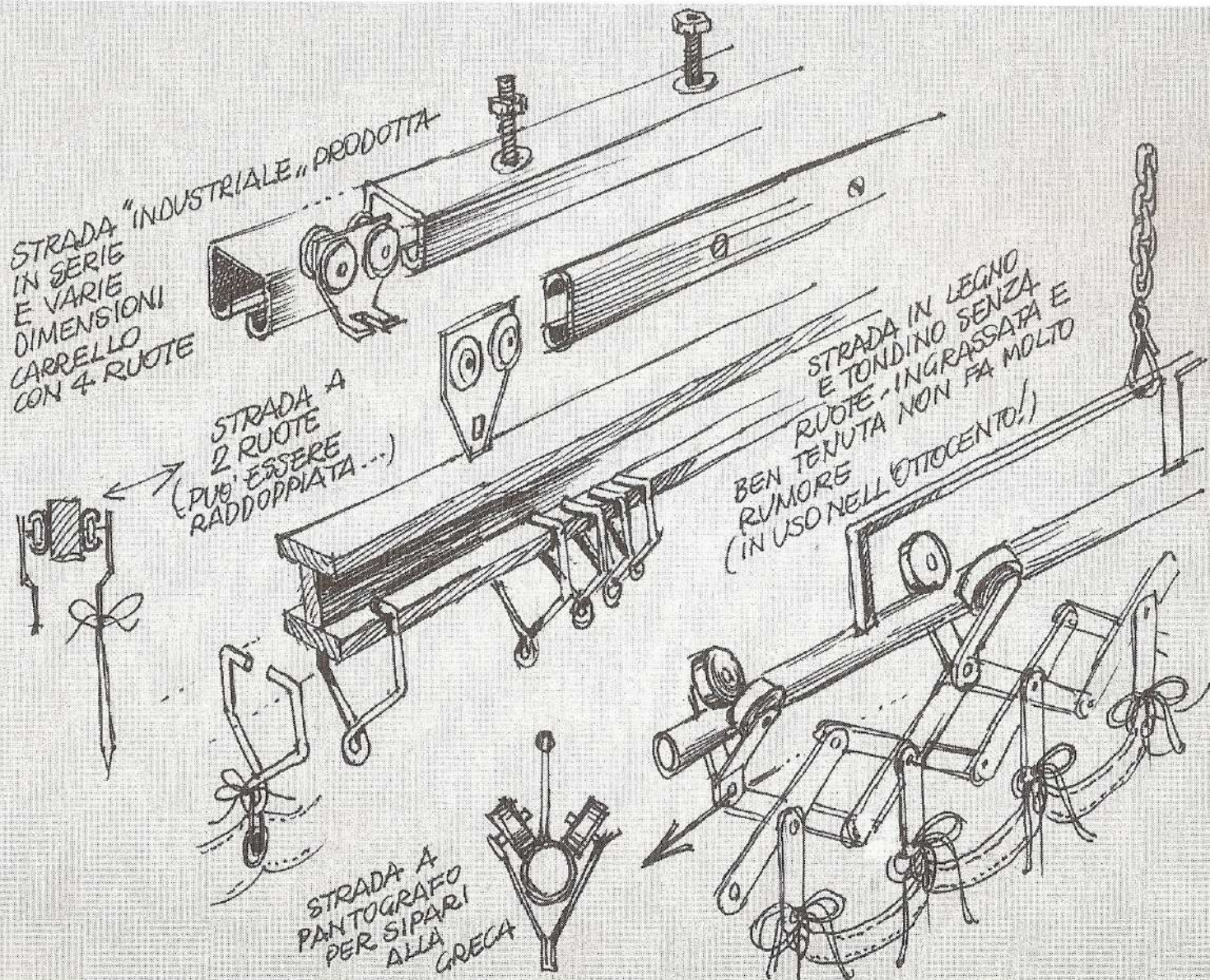

Tav. 35

CARRO CON RUOTE FISSE  
CORRE SOLO AVANTI  
E INDIETRO

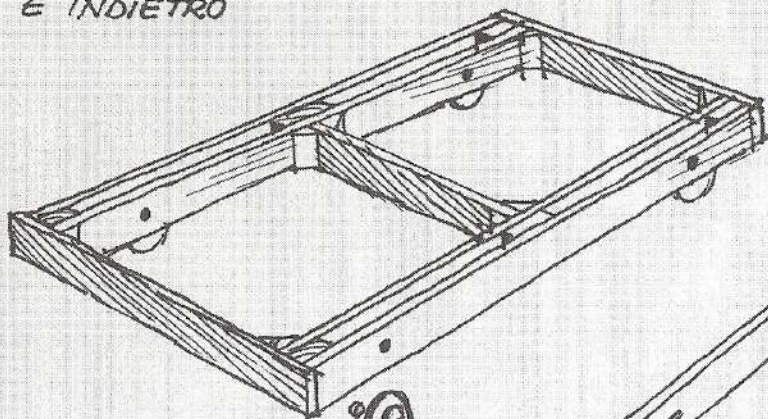

CARRO CON RUOTE  
PIVOTTANTI O MATTE  
CORRE IN TUTTE LE  
DIREZIONI

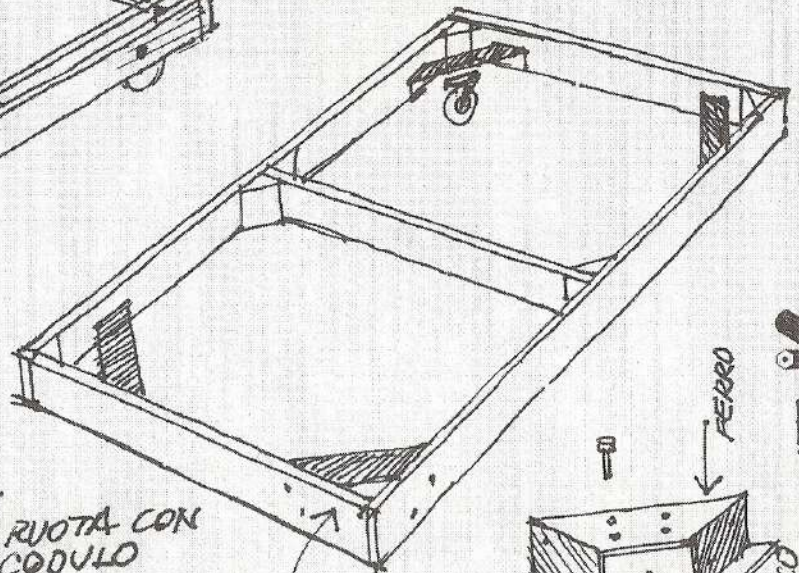

RUOTA FISSA



RUOTA  
PIVOTTANTE



RUOTA CON  
CODULO



RUOTE E CARRI

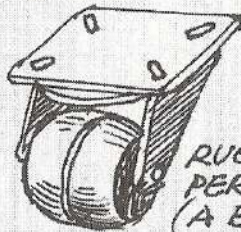

RUOTA SPECIALE  
PER TEATRO  
(A BOTTE  
COMPOSTA DA DUE  
ANELLI RASTREMATI)

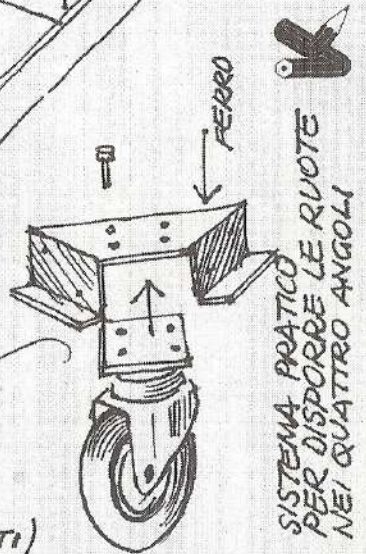

SISTEMA PRATICO  
PER DISPORRE LE RUOTE  
NEI QUATTRO ANGOLI

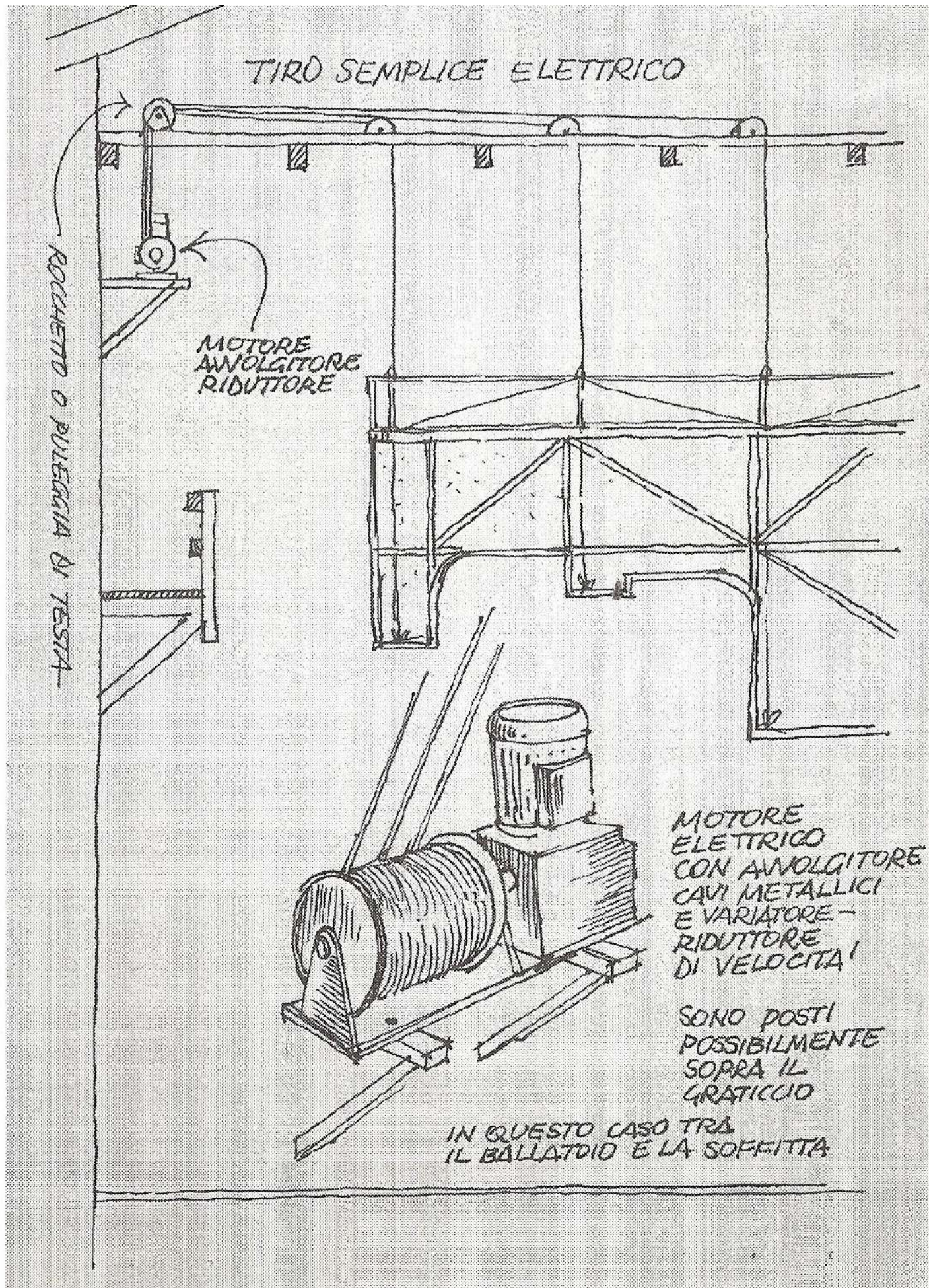

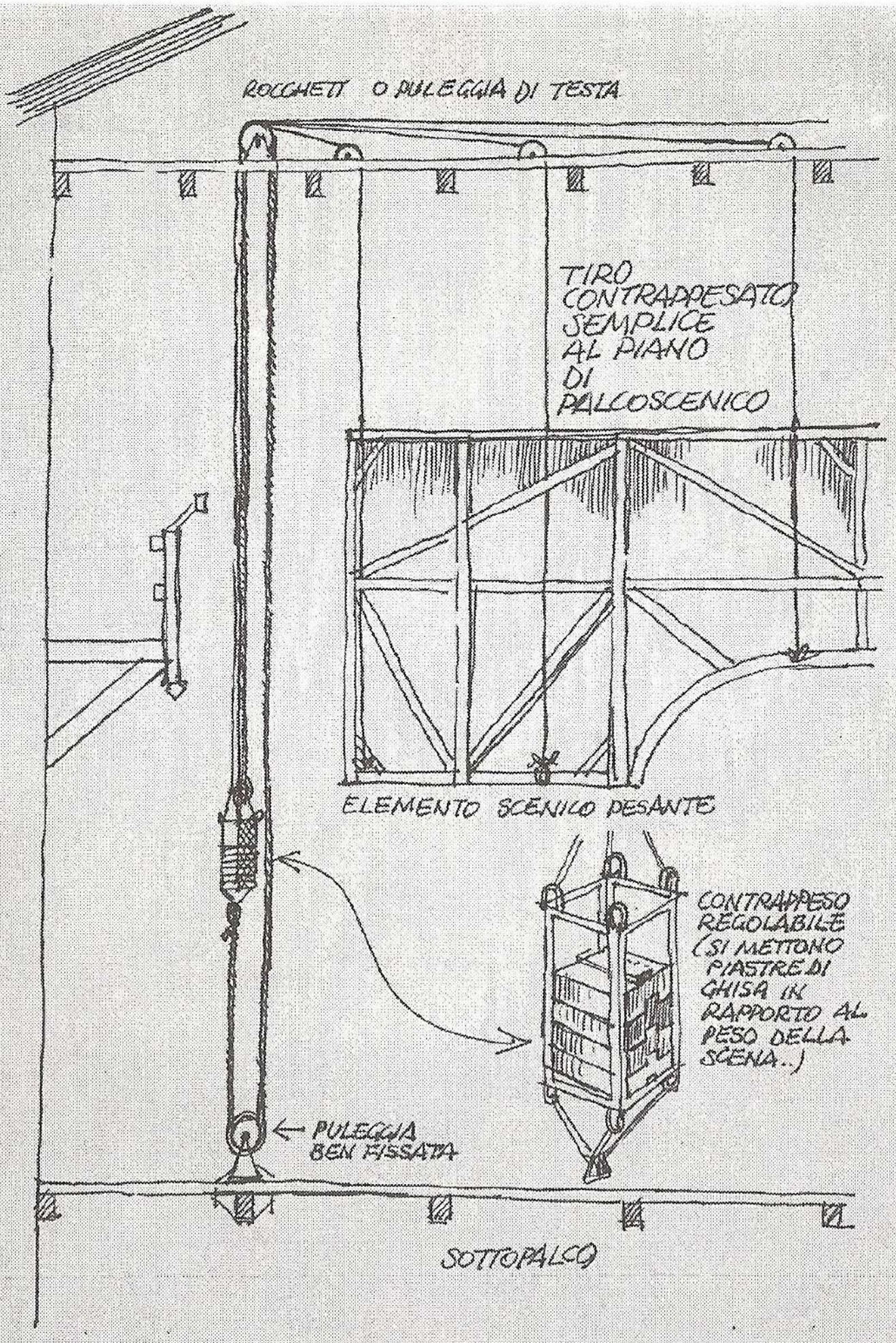

ESEMPIO CLASSICO DI SCENA MUTEVOLE  
RIPRESA CON SUCCESSO DA M. BALO'  
IN "EDDA GABLER"

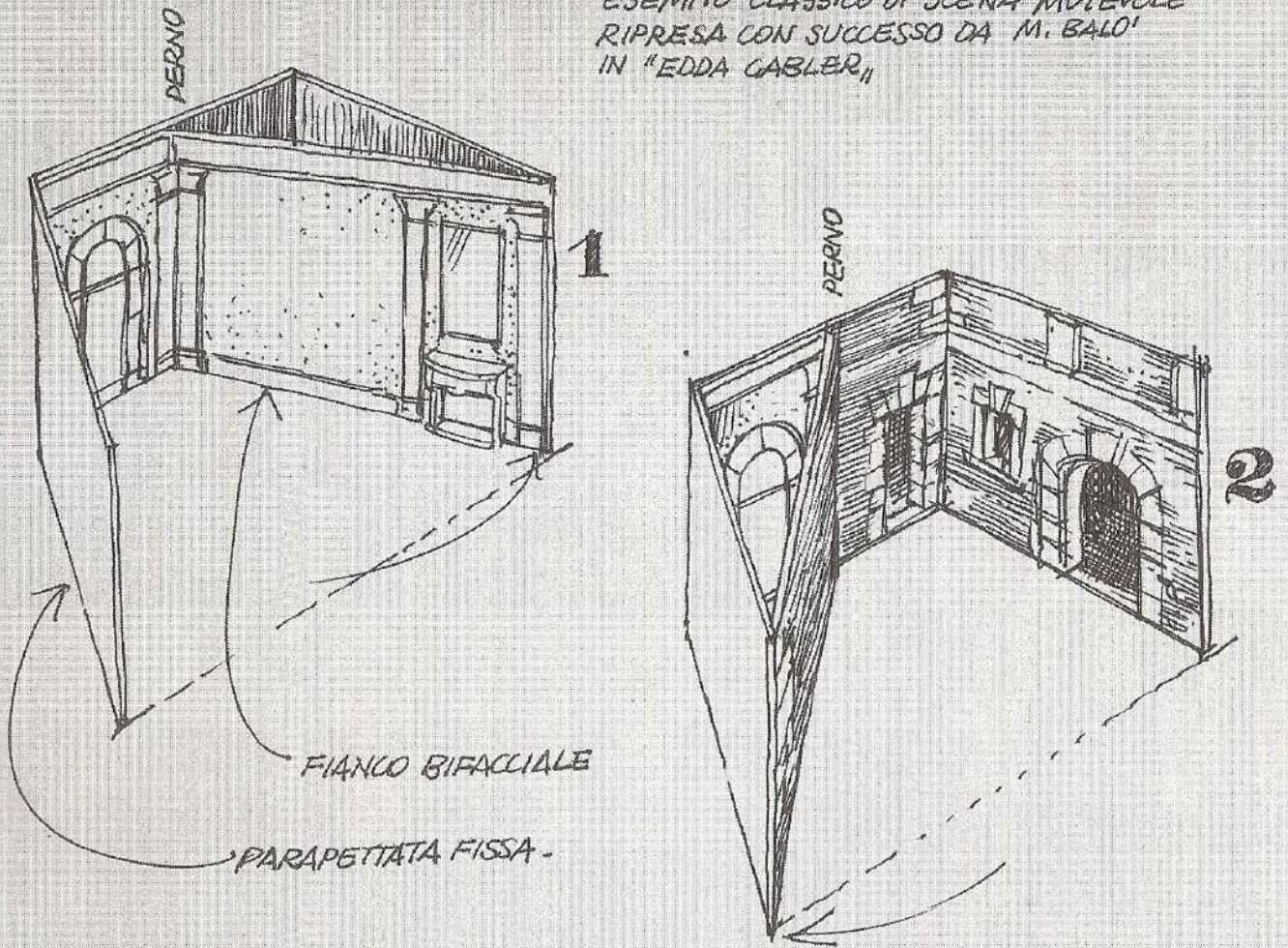

3 SCENE COSTRUITE SU PIATTAVORMA CIRCOLARE GIREVOLE  
 POTREBBERO ESSERE  
 ANCHE 2 - E CON MOLTO  
 INGEGNO 4!!

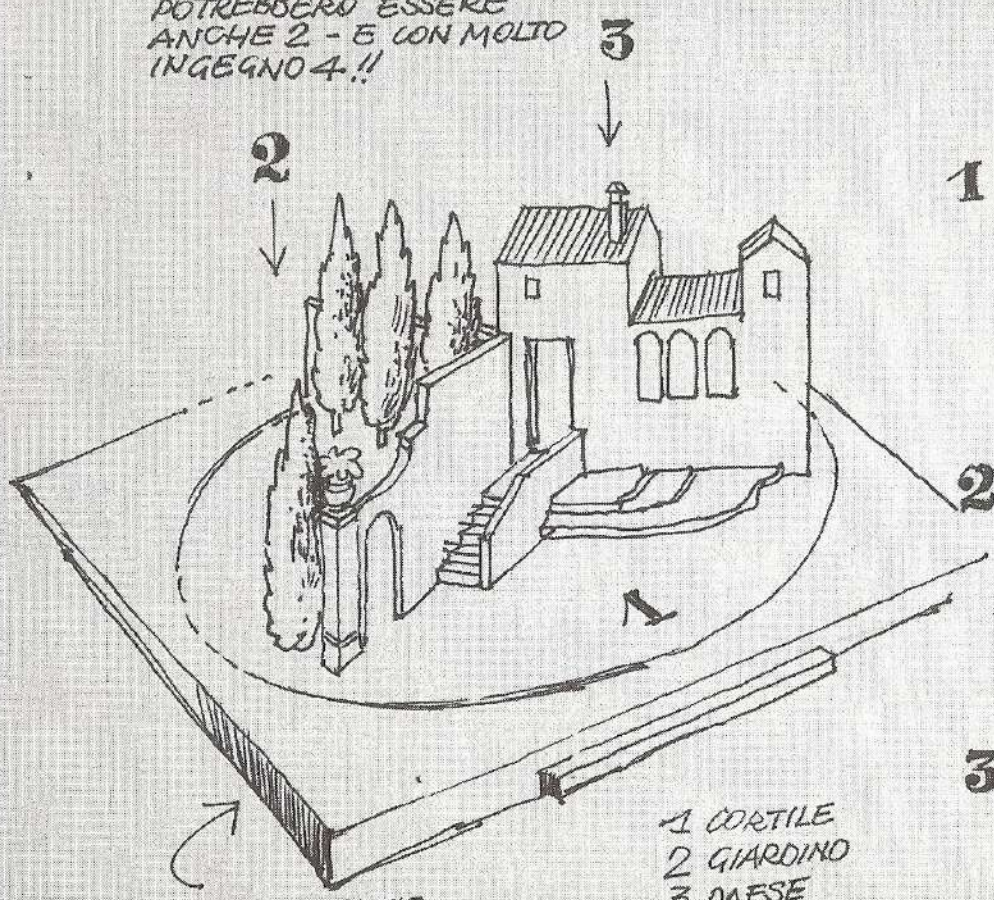

CONTRO DECLIVIO  
 (MANTIENE LE SCENE  
 A PIOMBO)

- 1 CORTILE
- 2 GIARDINO
- 3 PAESE

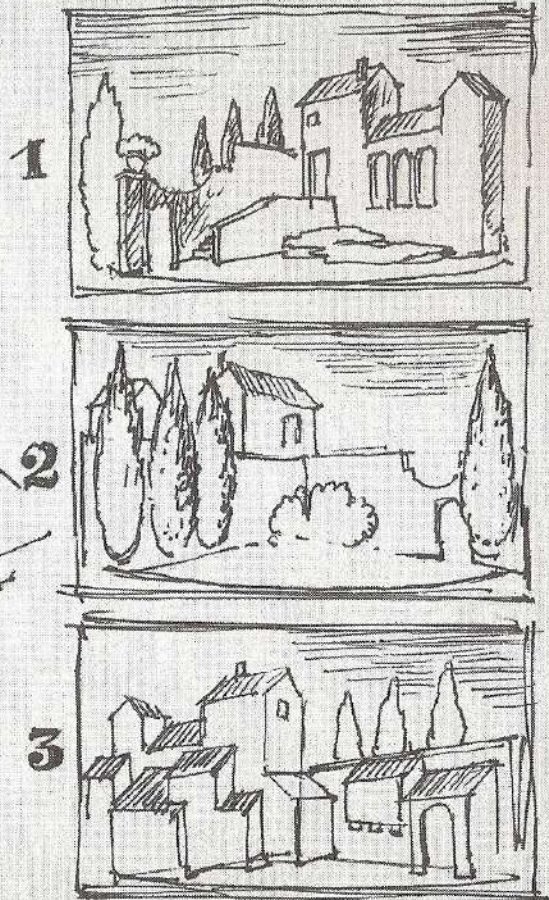



ISPIRATO A UN FAMOSO SPETTACOLO  
DI L. JOUVET "LA SCUOLA DELLE MOGLI"  
DI MOLIÈRE  
UN FALSTAFF REALIZZATO A SARAJEVO (1965)

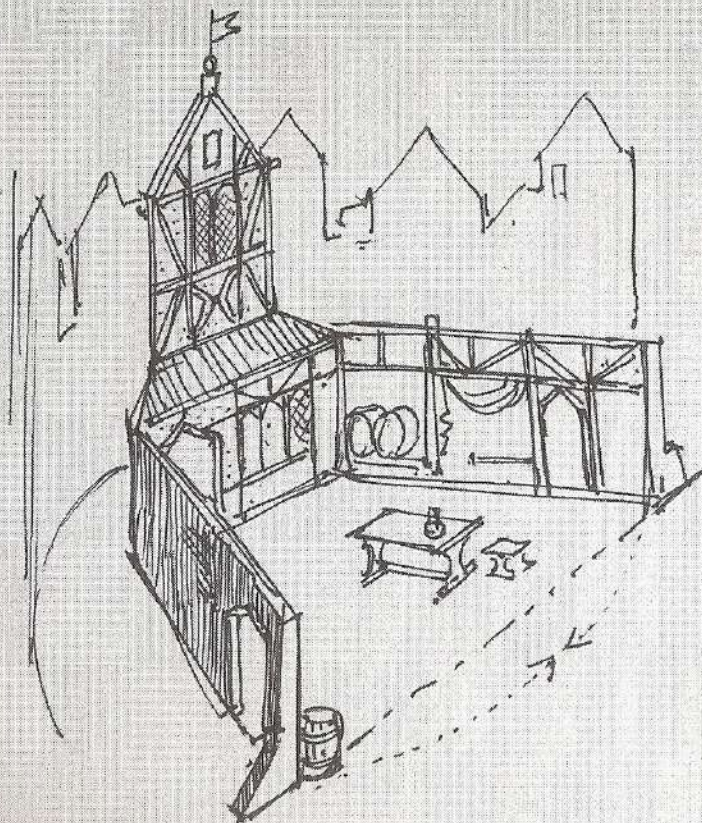

INTERNO ED ESTERNO OSTERIA  
INTERNO CASA DI FORD (MODIFICANDO  
L'INTERNO DELL'OSTERIA)  
ESTERNO BOSCO



UNA  
GRANDE  
QUERCIA  
SI COMPONEVA  
AL CENTRO E  
NASCONDEVA  
LA COSTRUZIONE

CON LO STESSO PRINCIPIO UN BUDN RIGOLETTO ALLA ROCCA  
DI RAVENNA NEGLI ANNI 70. SEMPRE DI KOVÁČEVIĆ

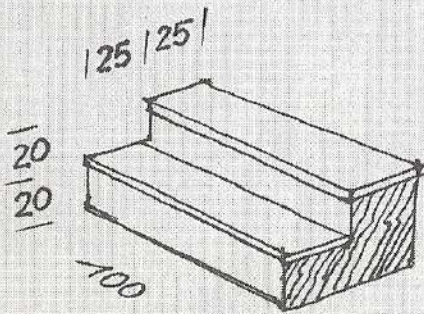

SCALE SEMPLICI  
 MODULARI  
 A STRUTTURA FISSA  
 AL COMUNALE DI FIRENZE  
 IL MODULO IN ALTEZZA  
 E' DI CM. 15+15+15 ECL

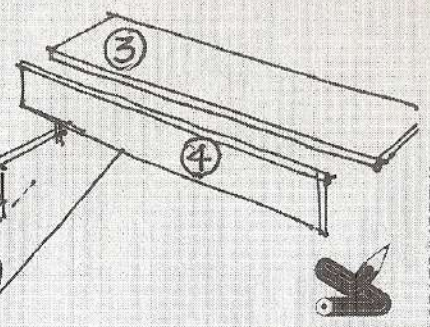
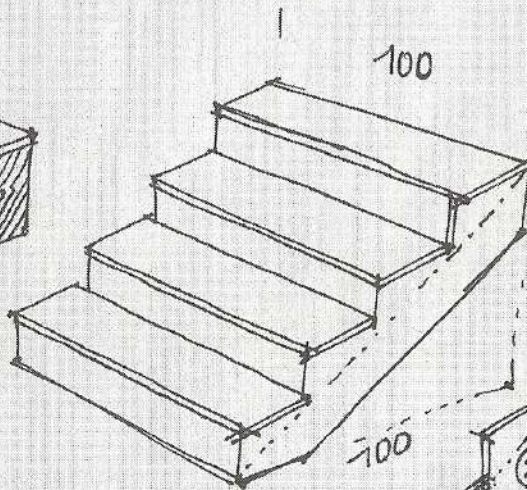

- 1 GATTELLO
- 2 COSCIALE
- 3 PIANO GRADINO
- 4 FRONTALINO

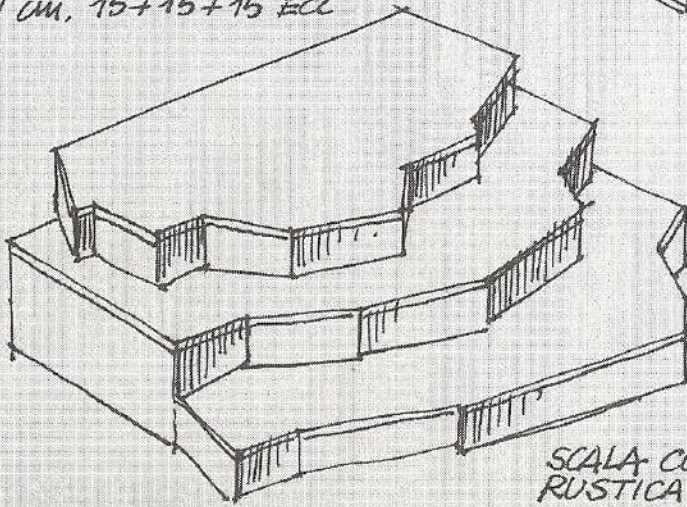

SCALA COMPLESSA  
 RUSTICA (VA TRATTATA MOLTO  
 DALL' SCENOGRFO)

NORMALMENTE LA LARGHEZZA DELLA FRATINA E' 60/70 CM, TALE DA CONSENTIRE UN GRADINO DI 2.5/3 CM DI SPESSORE SENZA RINFORZI

- 1 COSCIALE
- 2 GRADINO
- 3 CORRIMANO/MANTEGNO CON INNESTO A BAIONETTA
- 4 CERNIERE O PIASTRINI PER BLOCCAGGIO A TERRA E SUI PRATICABILI

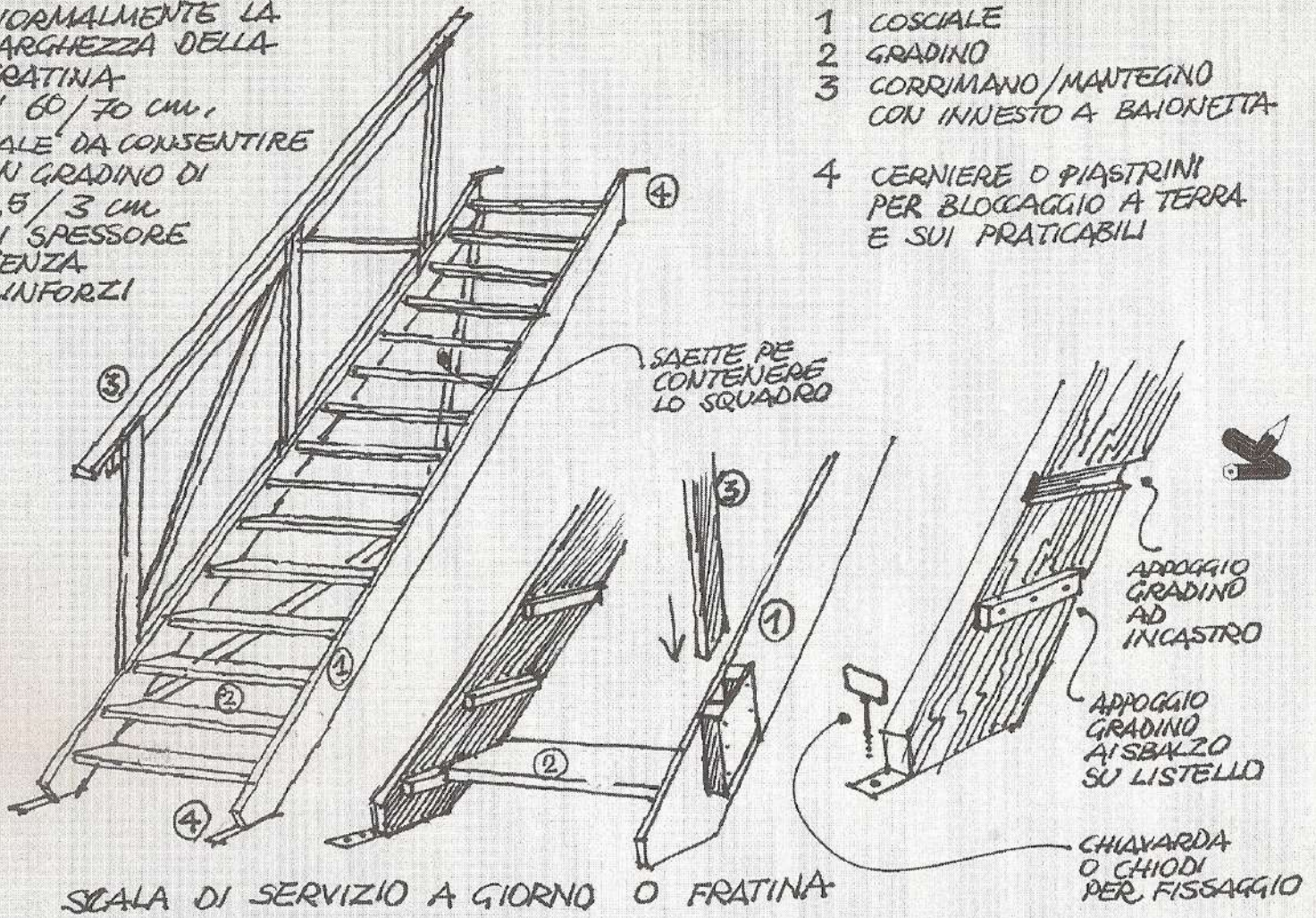

Tav. 44

SCALE

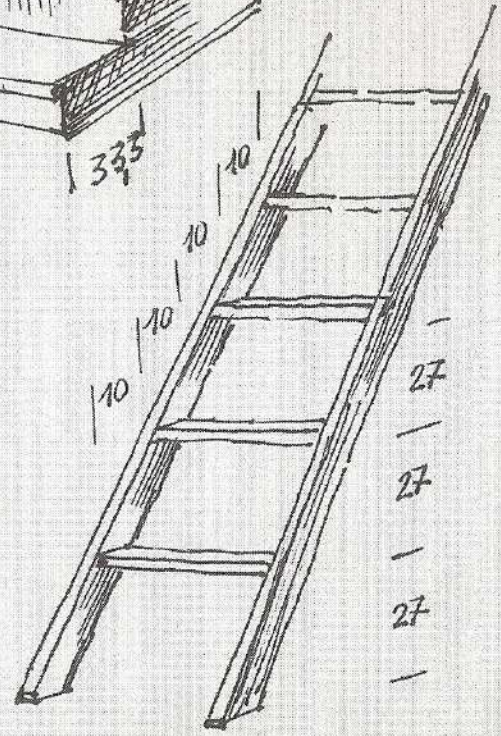
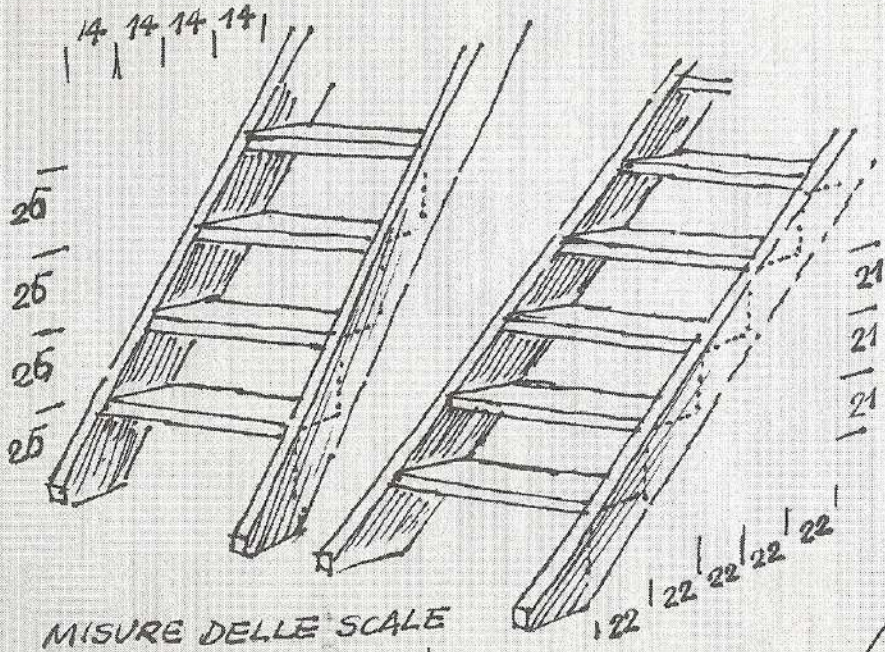
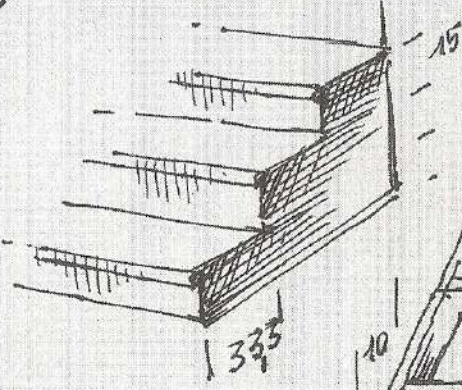
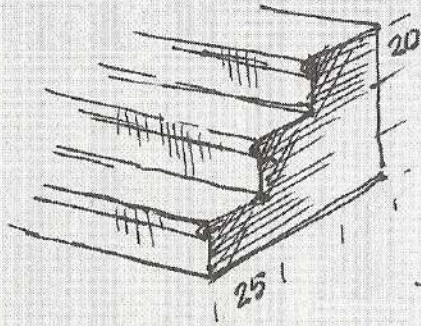

MISURE DELLE SCALE  
 DUE ALZATE PIU' UNA  
 PEDATA DEVONO DARE LA TOTALE di cui. 64!



PALCOSCENICO ATTREZZATISSIMO CON PIANI COMPLETI DI PALCOSCENICO  
SPOSTABILI AVANTI E INDIETRO E SOPRA E SOTTO

STATSOOPER VIENNA - OPERA BASTILLE...

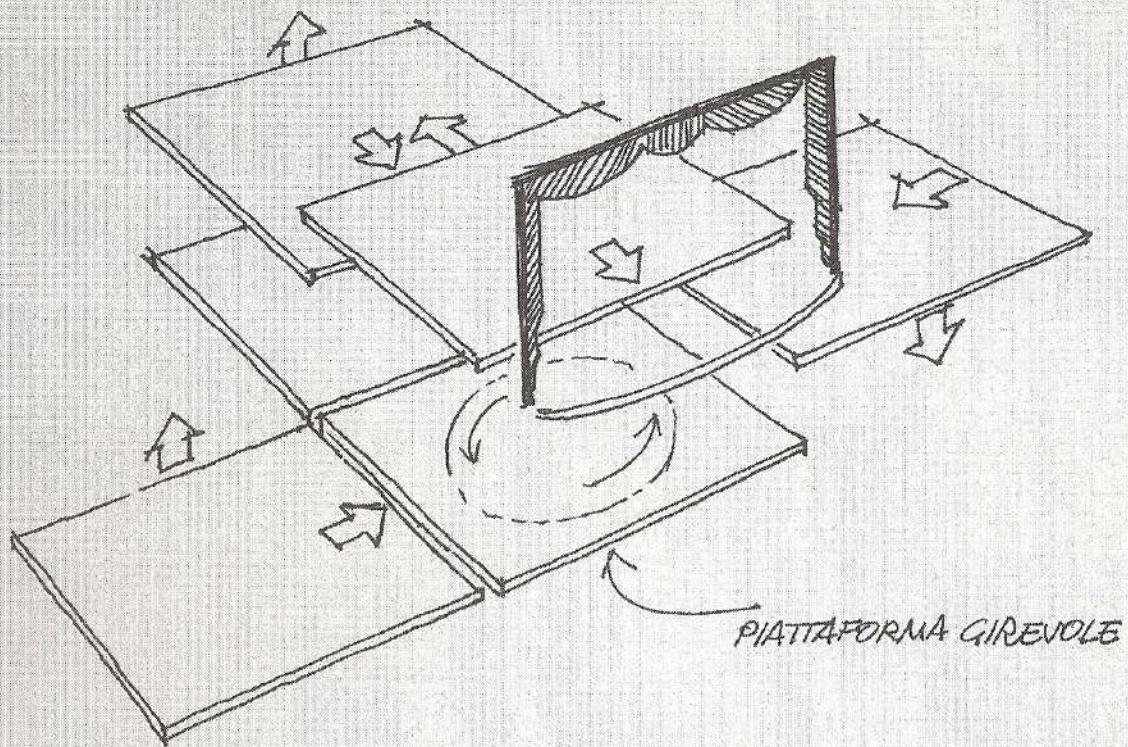

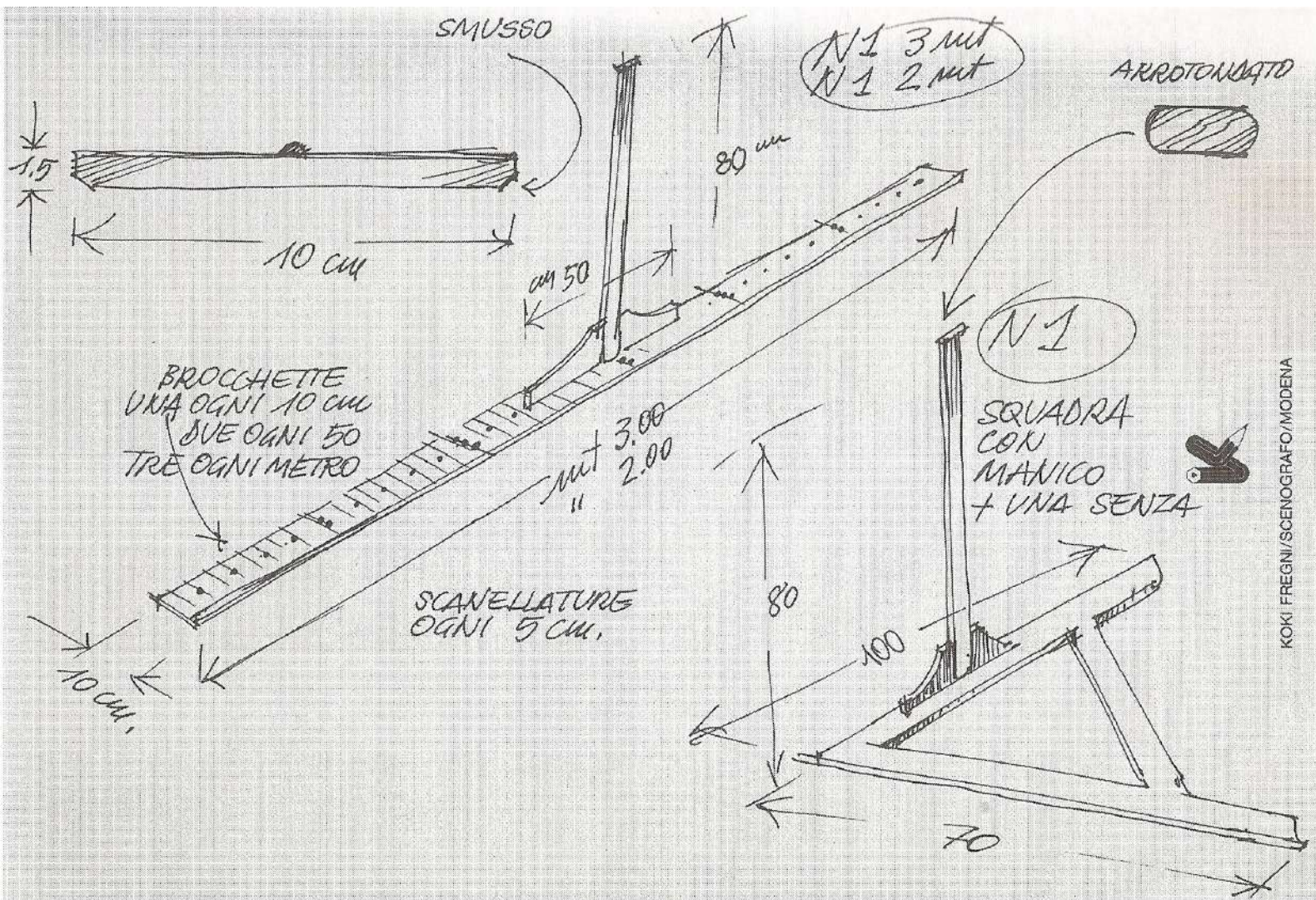

KOKI FREGNI/SCENOGRFO/MODENA

Tav. 47

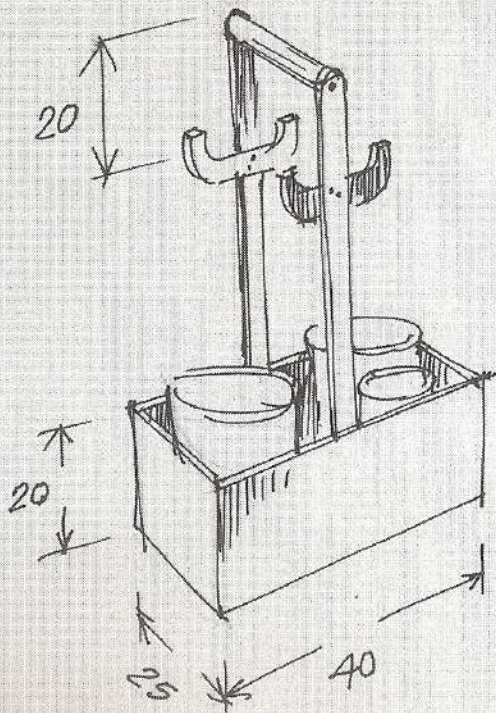

CASSETTA  
PORTA BIDONCINI  
E PENNELLI

N° 1

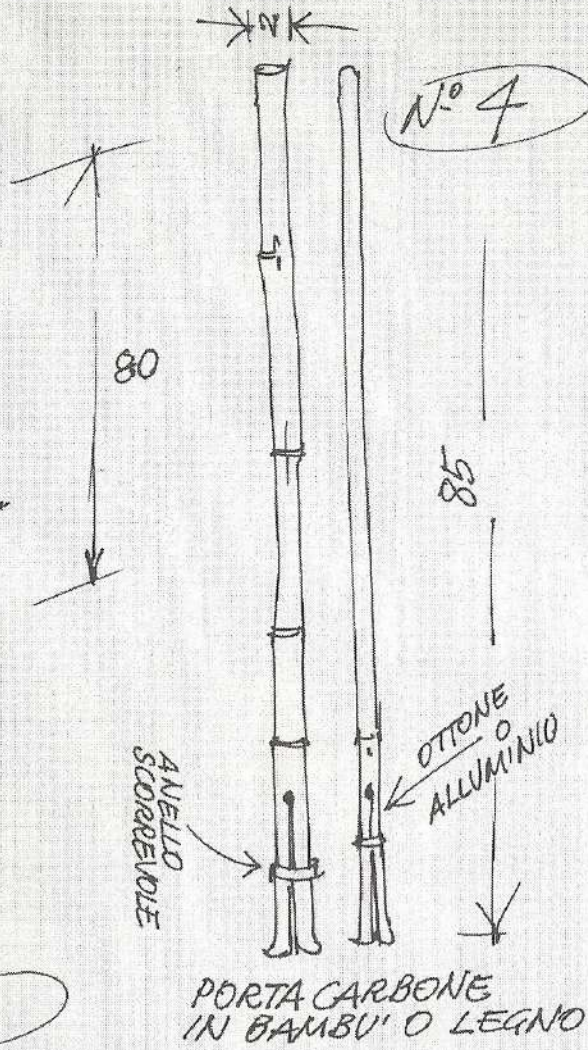

ANELLO  
SCORREVOLE

N° 4

85

OTTONE  
O  
ALLUMINIO

PORTA CARBONE  
IN BAMBU' O LEGNO

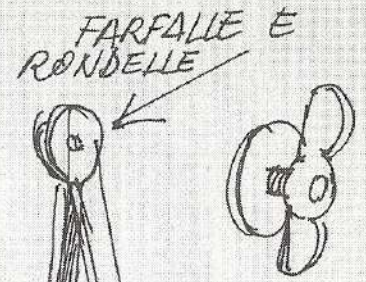

FARFALLE E  
RONDELLE

COMPASSO

N° 1

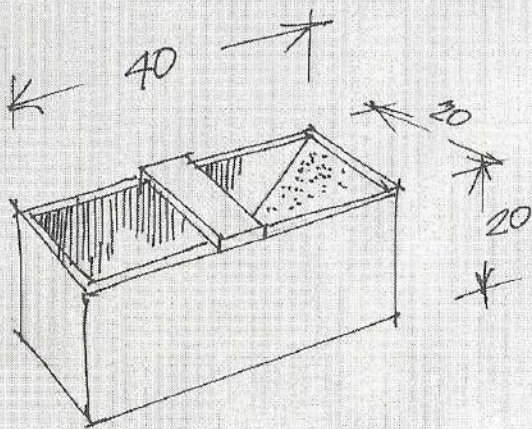

CASSETTA  
PORTACARBONE (N.1)

+ CARBONE IN STECCHE  
2 Kg.

+ CARBONCINI  
E GESSO  
SU STECCHE  
ADEGUATE

VARIE  
MISURE  
DA  
CONCORDARE

+ PENNELLI  
ORDINARI CHE  
VANNO  
IMMANICATI

SPUGNE  
BARATTOLI  
STRACCI

VINAVIL (NPC  
STELLA  
AZZURRA)  
5 Kg.

COLLA DA  
PARATI  
(GLUTOLIN.?)

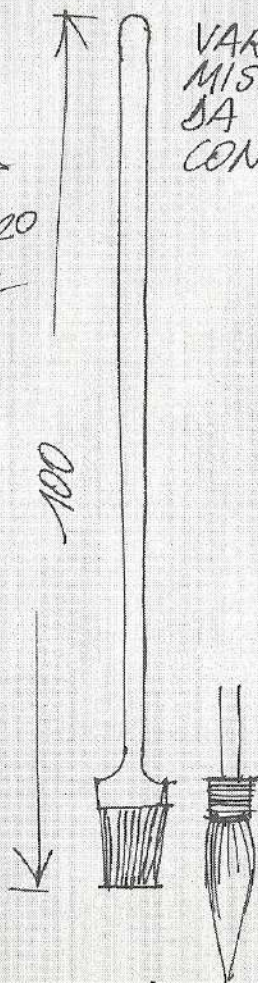

PENNELLI PER SCENOGR.





N.1

# TAVOLOZZA

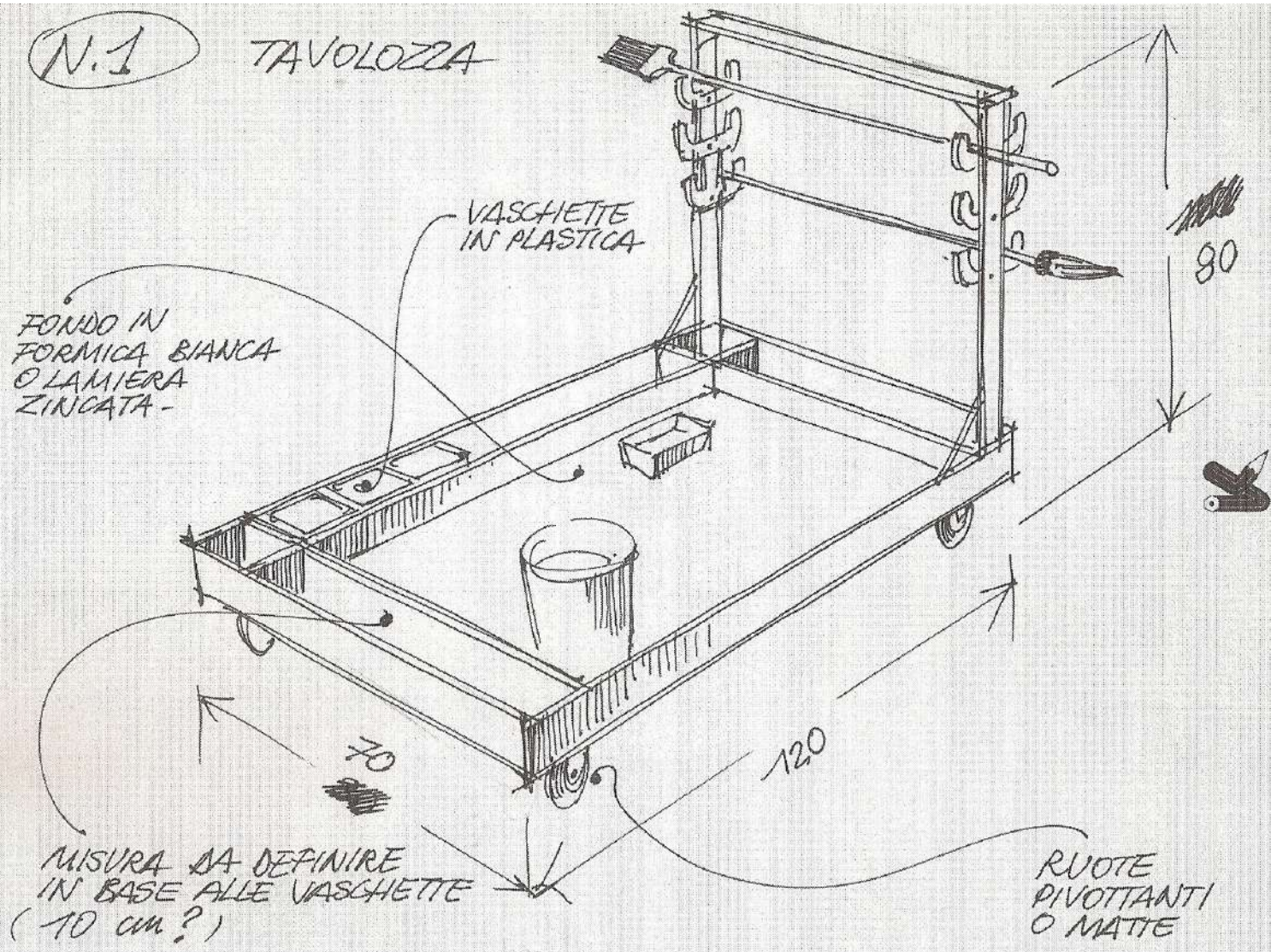

VASCHEE IN PLASTICA

FONDO IN FORMICA BIANCA O LAMIERA ZINCATA -

80

70

120

MISURA DA DEFINIRE IN BASE ALLE VASCHEE (10 CM?)

RUOTE PIVOTTANTI O MATTE

Tav. 50

N. 1

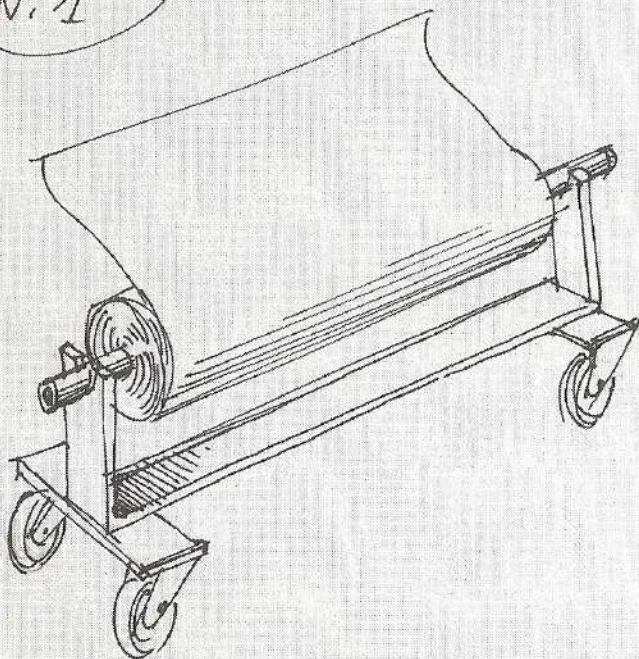

ROTOLO CARTA  
MONOLUCIDA - BIANCA  
(100 GR.?)  
E PORTAROTOLO  
ADEGUATO ALLA MISURA  
DELLA CARTA - (120? 140? 100?)

SEGATURA  
GESSO DI MEUDON (O BOLOGNA)  
RULLO  
SPATOLA  
BASTONI PER MESCOGLARE  
GULIPREME O GOMMAPIUMA  
BOSTIK SUPERCHIARO  
GARZA  
CENCIO NONNA  
ANILINE  
ORI  
BRONZI  
VERNICE BRONZARE  
TULLES  
RETE  
NASTRI ADESIVI  
TRINCETTI

TELA —  
(CATALOGO PERONI)



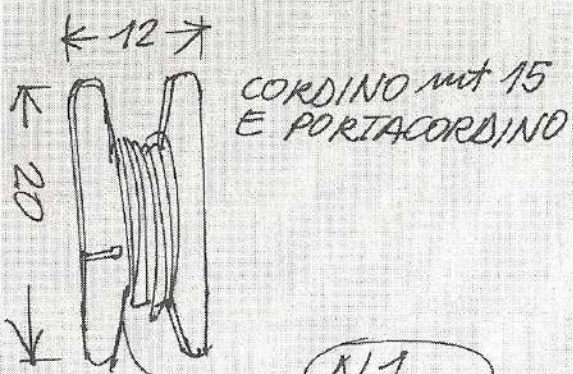

CORDINO mt 15  
E PORTACORDINO

N°1

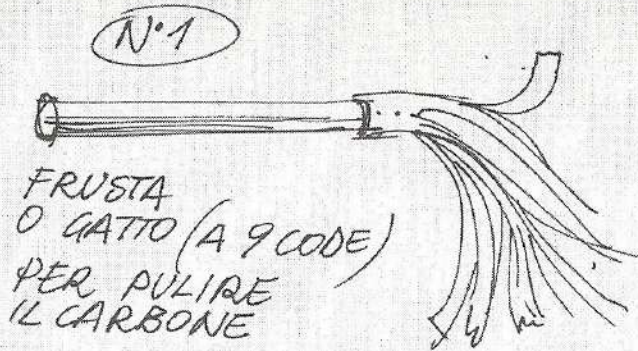

FRUSTA  
O CATTO (A 9 CODE)  
PER PULIRE  
IL CARBONE

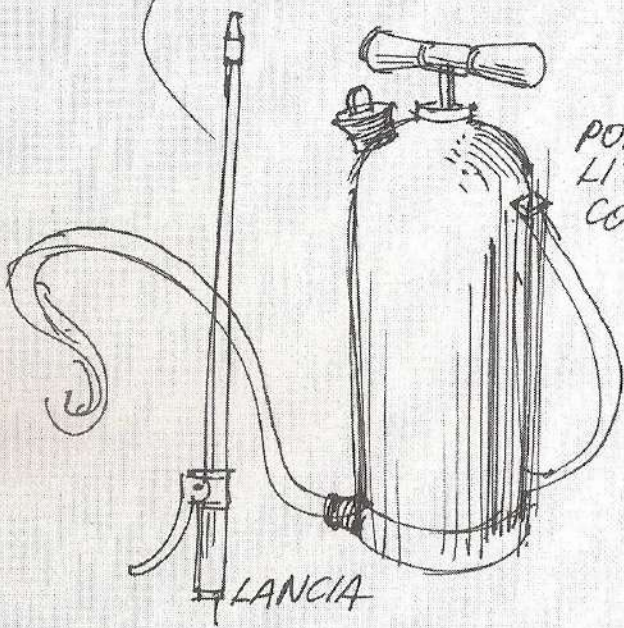

POMPA DA  
LITRI 6 CILINDRICA  
CON LANCIA  
ADEGUATA  
(TUTTO IN OTTONE!)



IMBUTO E COLO



DISEGNO DI PARALLELEPIPEDO SVILUPPATO SU TRE PIANI E RELATIVI RIBALTIMENTI (QUESTA È ANCHE UNA RAPPRESENTAZIONE IN ASSONOMETRIA)

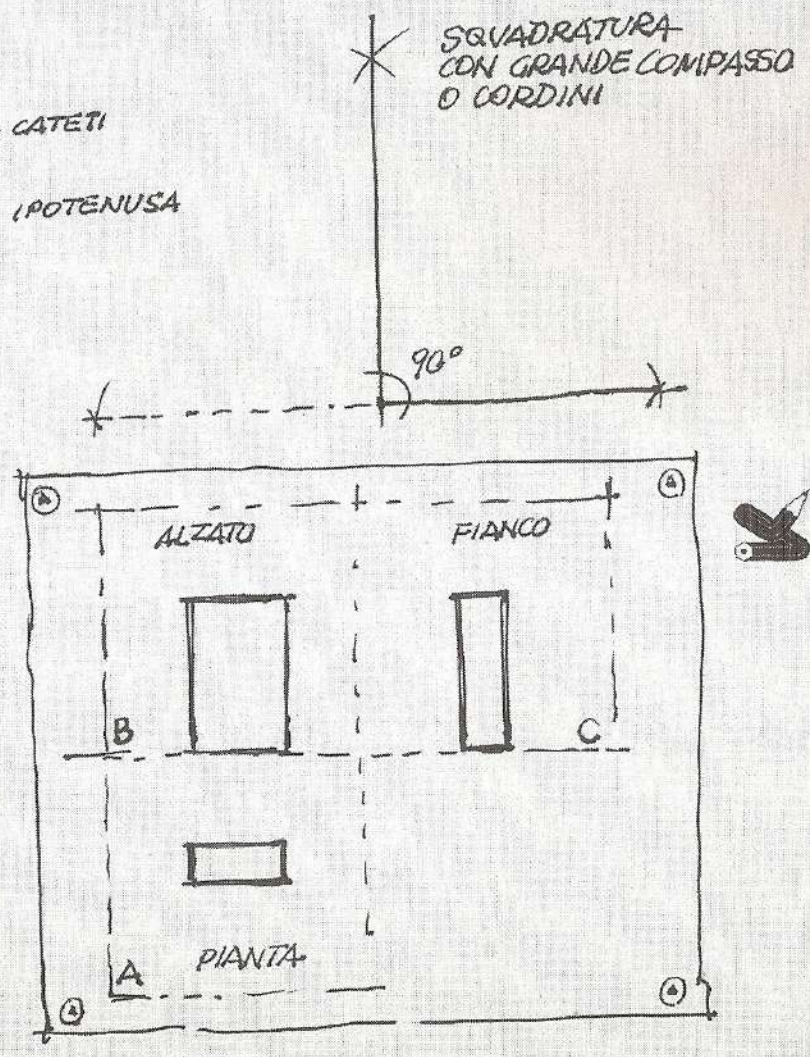
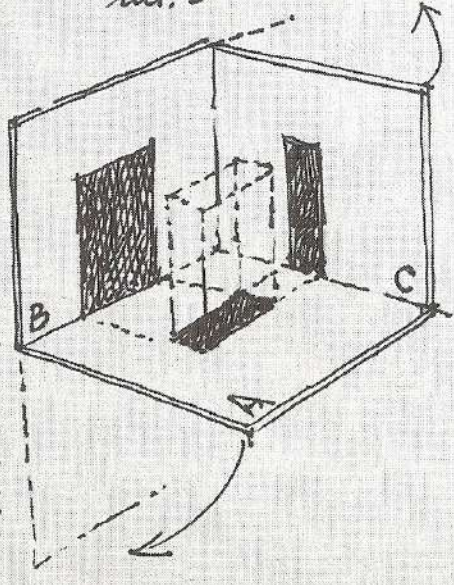
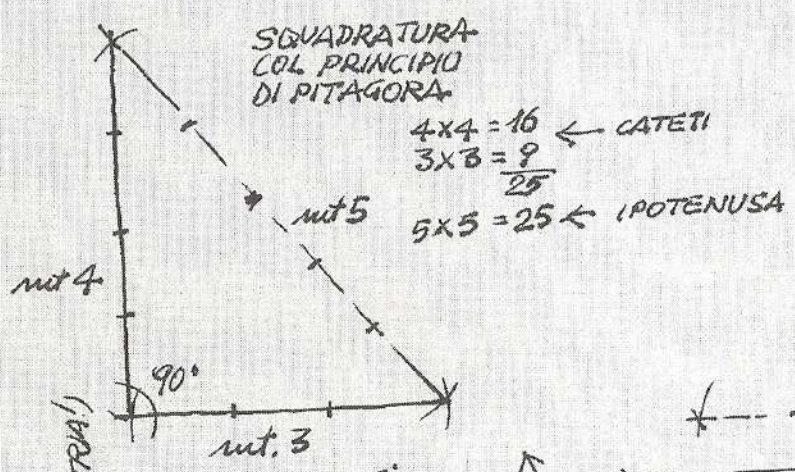

Tav. 53

ARNESI UTENSILI TRADIZIONALI  
PER MACCHINISTI

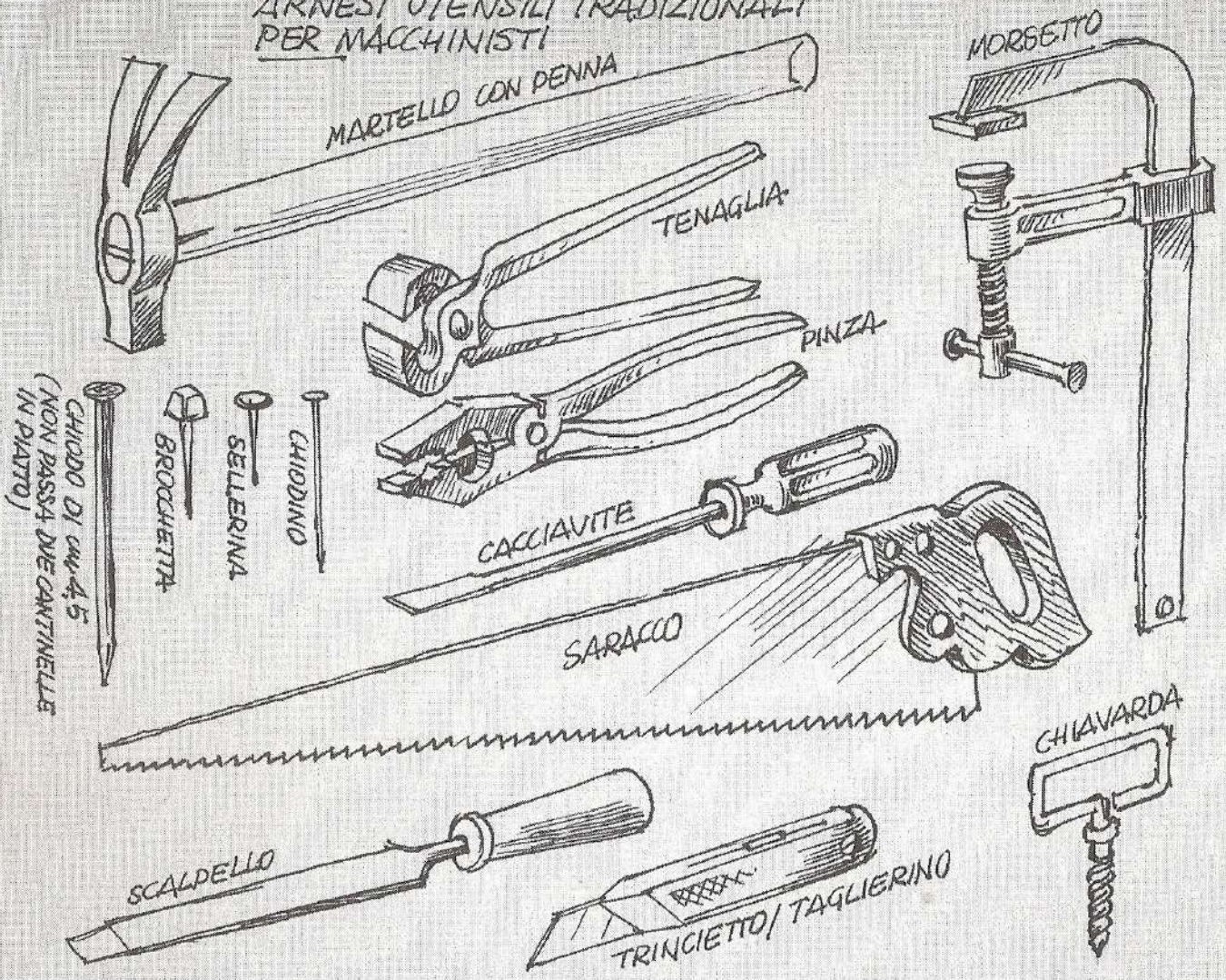

Tav. 54

TRONCATRICE  
SPECIALE PER  
CANTINELLE  
E LISTELLI

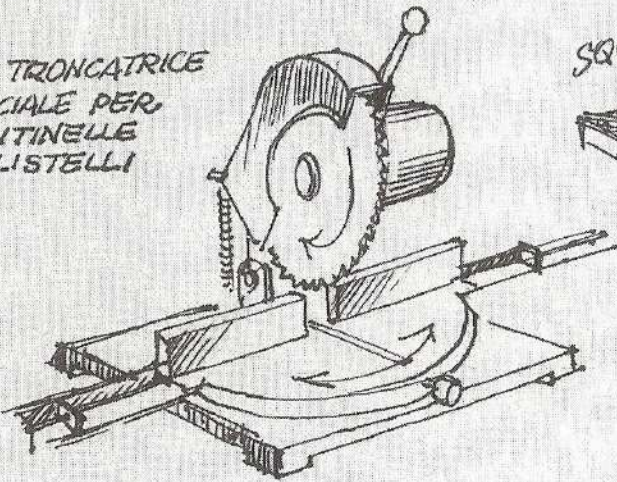

SQUADRA IN  
METALLO

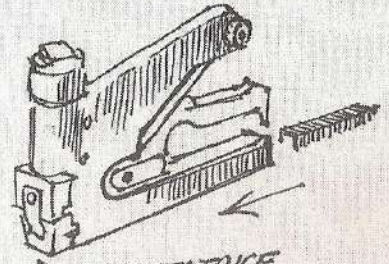
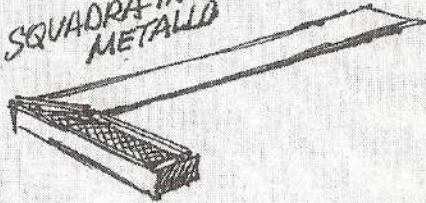

PUNTATRICE  
(C'E' ANCHE AD  
ARIA COMPRESSA)  
BUONA PER  
APPLICARE TELA  
O COMPENSATI  
AI TELAI

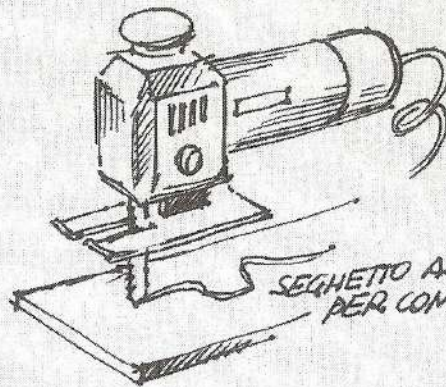

SEGHETTO ALTERNATIVO  
PER COMPENSATI

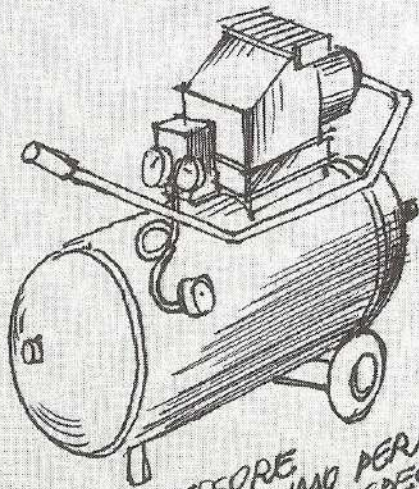

COMPRESSORE  
(BUONISSIMO PER  
UTENSILI SPECIALI)

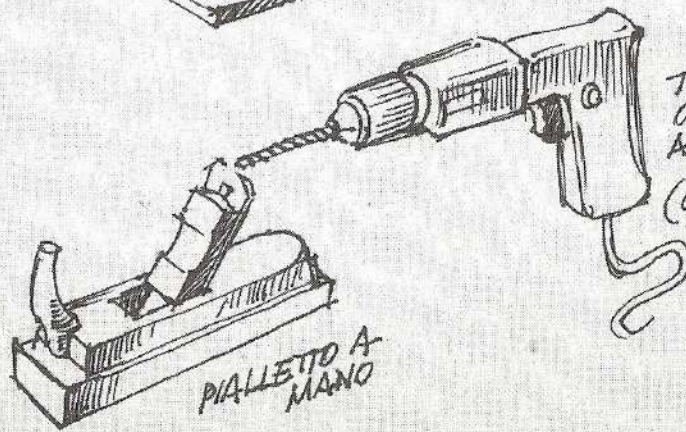

TRAPANO  
O  
AVITATORE  
(C'E' ANCHE  
A BATTERIA!)

PIALLETTO A  
MANO

C'E' ANCHE LA MACCHINA PER LA NEVE! (SCHIUMA)

MACCHINA PER IL FUMO/NEBBIA  
AD OLIO SPECIALE

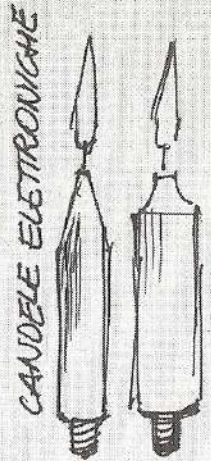
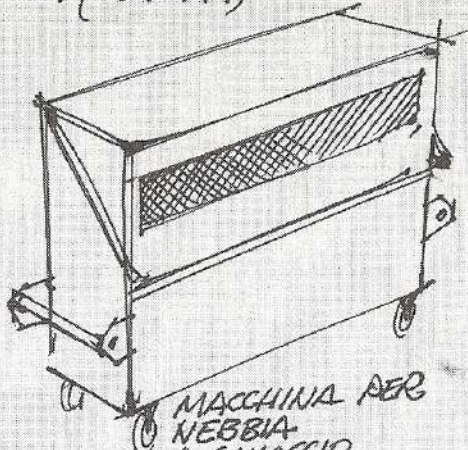
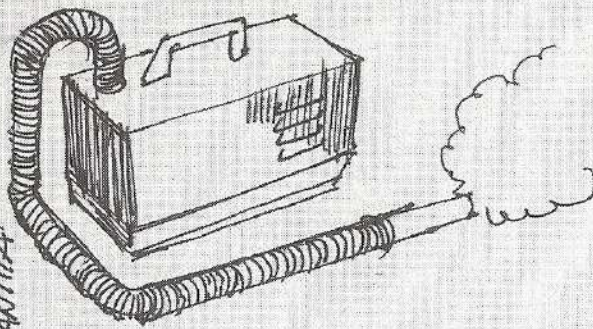

CANDELE ELETTRONICHE

MACCHINA PER  
NEBBIA  
A GHIACCIO  
SECCO

MACCHINA  
PER  
BOLLE  
DI  
SAPONE

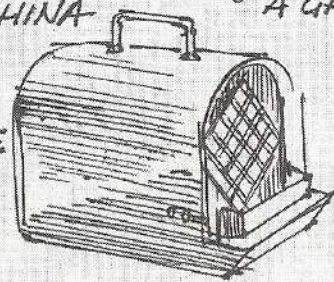

COMANDO  
ELETTRICO A  
DISTANZA PER  
QUALITA' E QUANTITA'

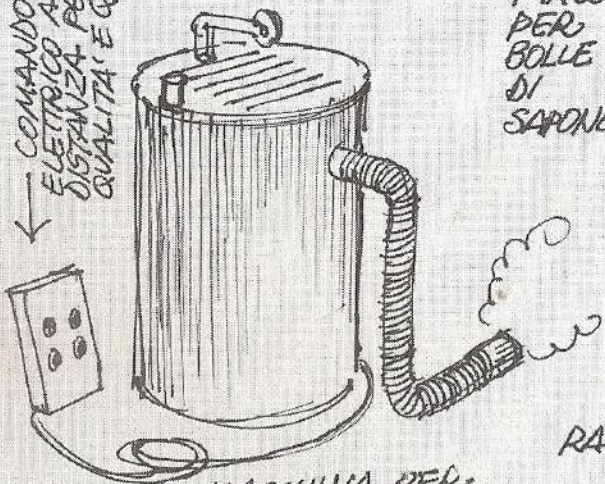

MACCHINA PER  
IL FUMO CHIMICA

PER  
RAGNIATELE

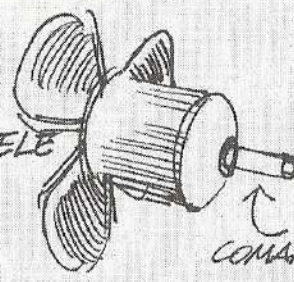

COMANDO CON TRAPANO

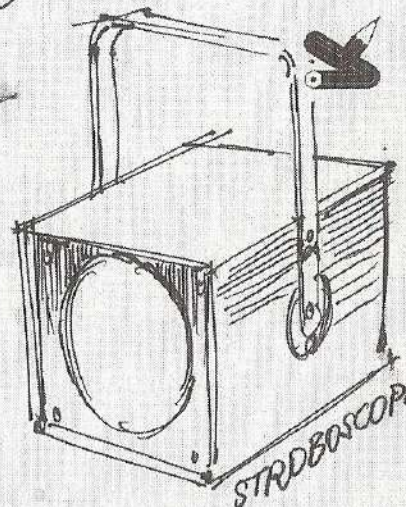

STROBOSCOPIO

KOKI FREGNI/SCENOGRAFO/MODENA

Tav. 56

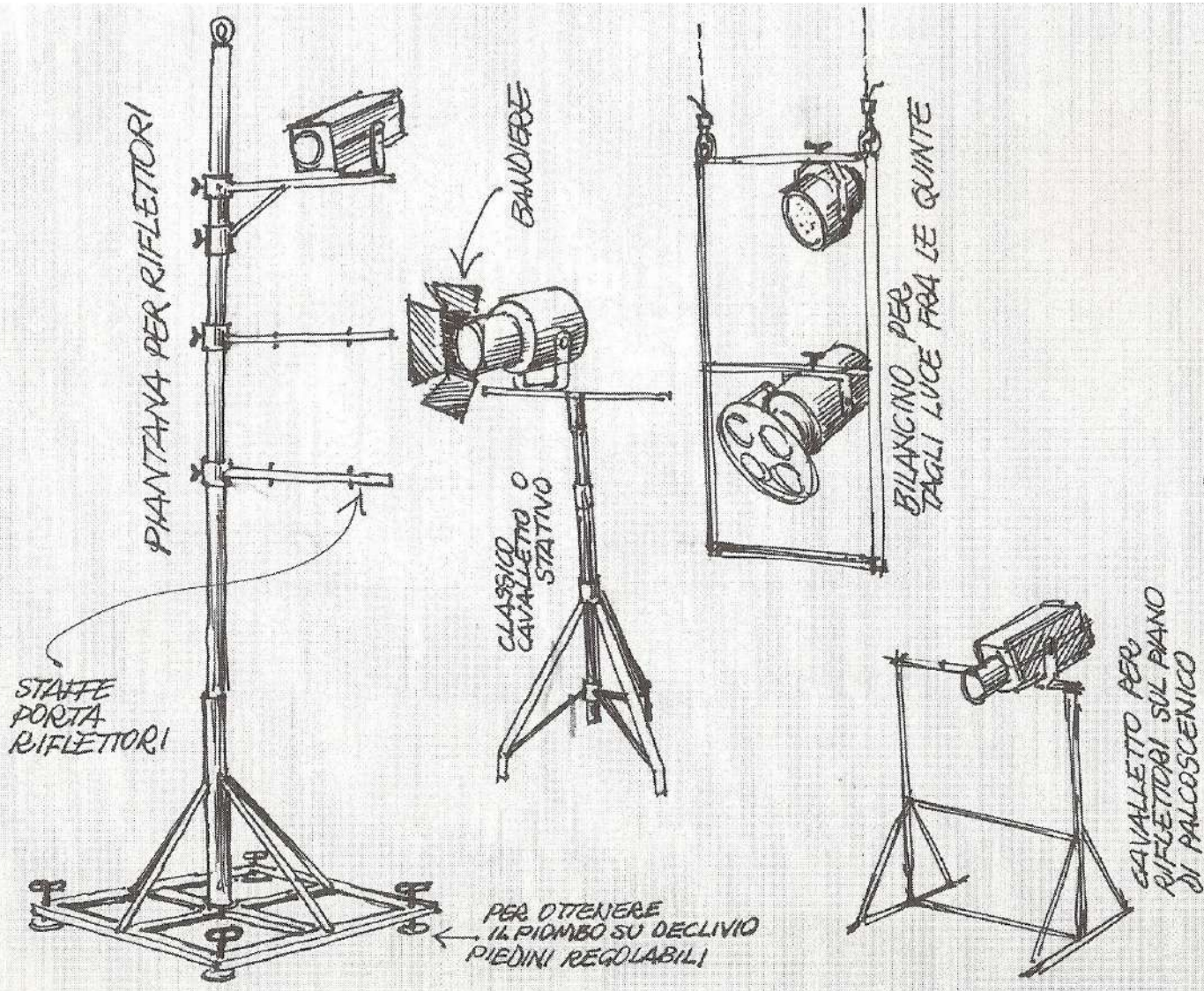

Tav. 57





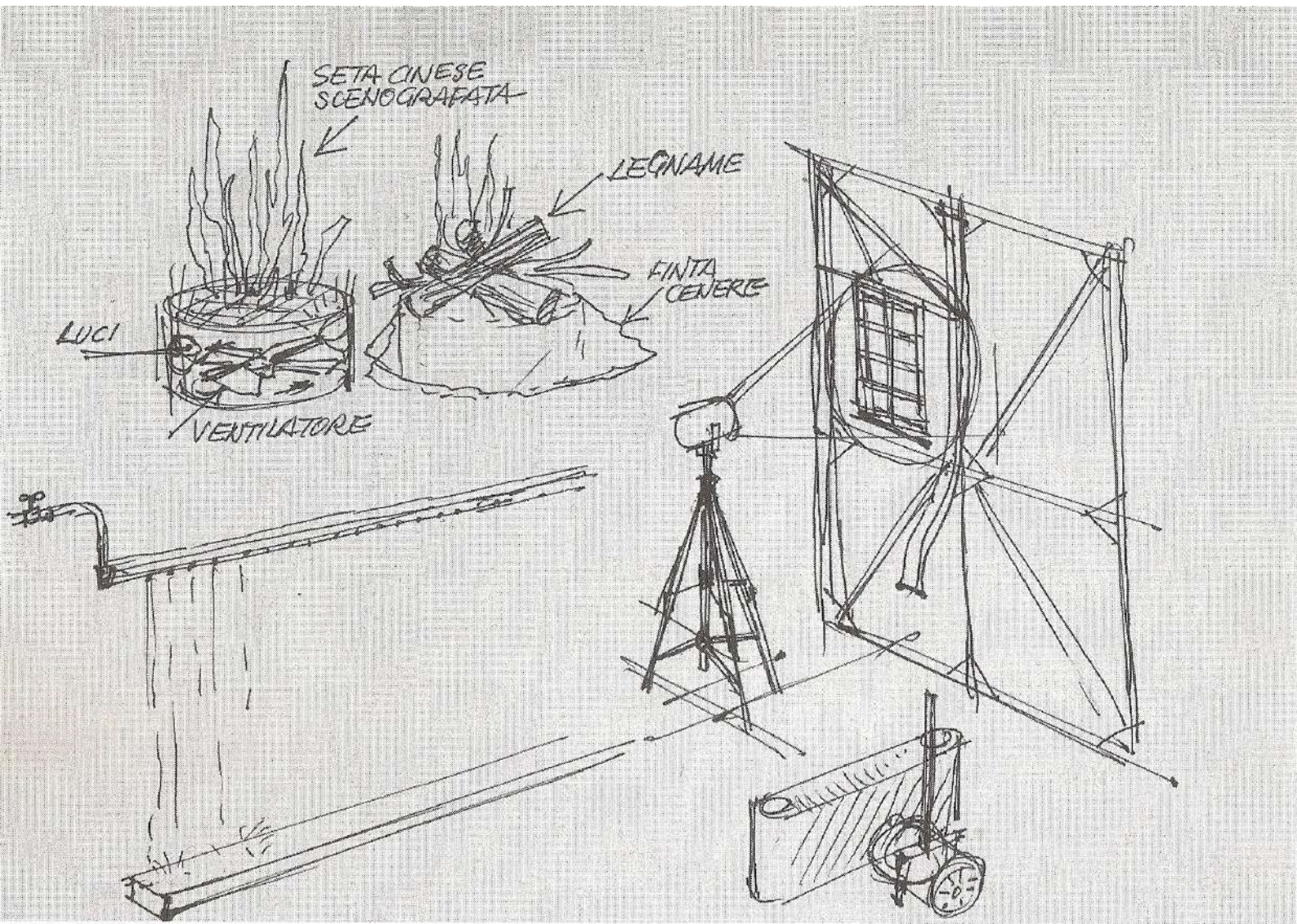

Tav. 58